

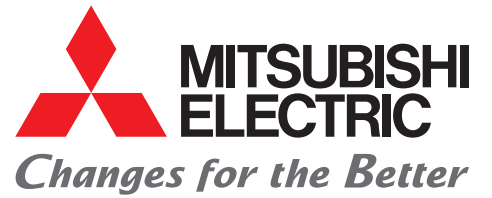

for a greener tomorrow



FACTORY AUTOMATION

SERVO AMPLIFIERS & MOTORS

MR-JE-AS HJ-KS/HJ-FS

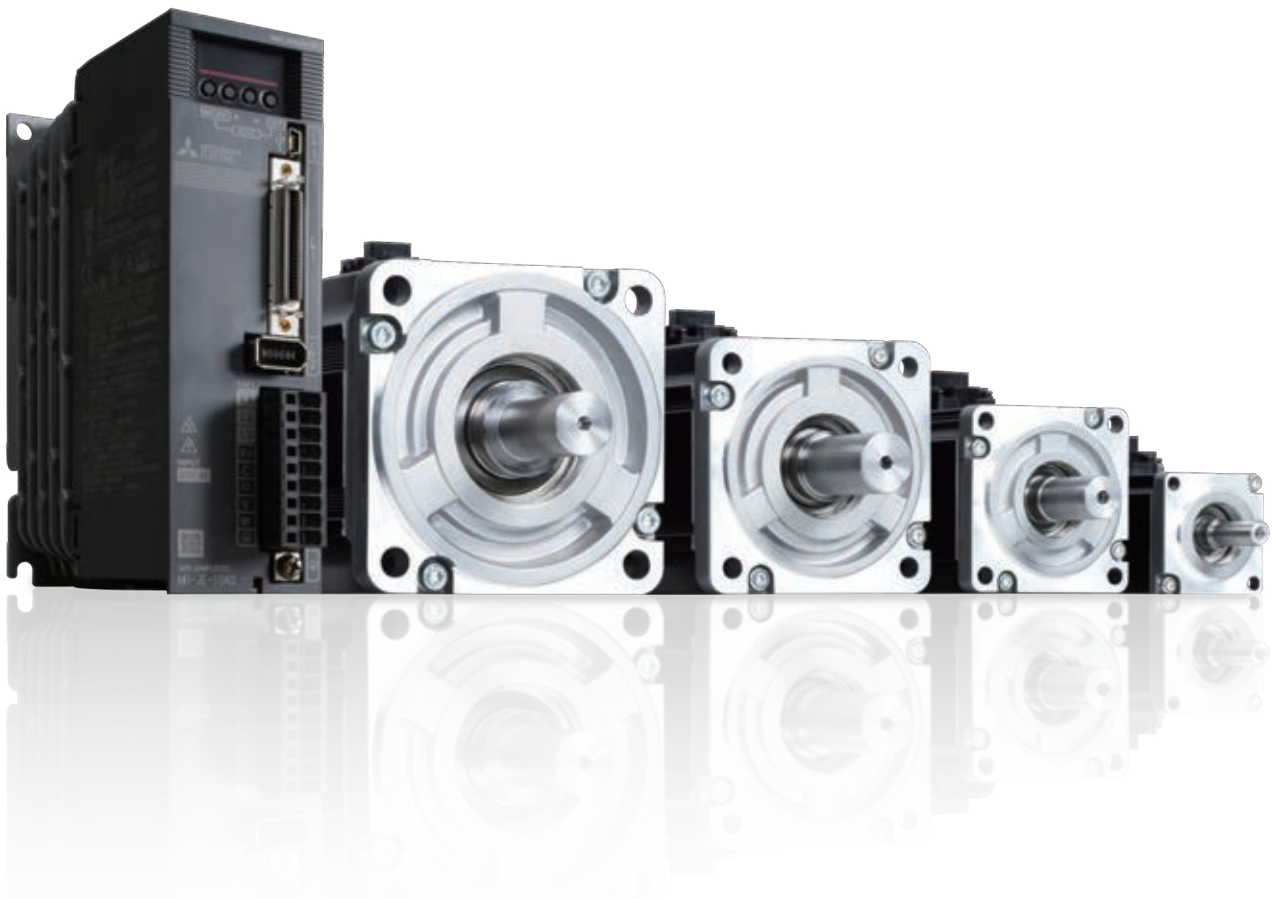

- Easy To Use
- High Performance
- Global Standard

GLOBAL IMPACT OF MITSUBISHI ELECTRIC



Through Mitsubishi Electric's vision, "Changes for the Better" are possible for a brighter future.

Changes for the Better

We bring together the best minds to create the best technologies. At Mitsubishi Electric, we understand that technology is the driving force of change in our lives. By bringing greater comfort to daily life, maximizing the efficiency of businesses and keeping things running across society, we integrate technology and innovation to bring changes for the better.

Mitsubishi Electric is involved in many areas including the following

Energy and Electric Systems

A wide range of power and electrical products from generators to large-scale displays.

Electronic Devices

A wide portfolio of cutting-edge semiconductor devices for systems and products.

Home Appliance

Dependable consumer products like air conditioners and home entertainment systems.

Information and Communication Systems

Commercial and consumer-centric equipment, products and systems.

Industrial Automation Systems

Maximizing productivity and efficiency with cutting-edge automation technology.

OVERVIEW

■ Features	4
■ Product Lines	5
■ FA Total System	6
■ Application Examples	7
■ Easy To Use	8
■ High Performance	12
■ Global Standard	14
■ Product Specifications	
Servo Amplifiers	1-1
Servo Motors	2-1
Option/Peripheral Equipment	3-1
Low-Voltage Switchgear/Wires	4-1
Product List	5-1
Cautions	6-1

Easier, More Flexible, A Step Forward in Productivity



Easy To Use



One-touch Tuning

Servo gains are adjusted with one-touch ease without a personal computer. The machine resonance suppression filter and the vibration suppression control filter are also automatically adjusted.

Advanced Vibration Suppression Control

Low-frequency residual vibration, etc., generated in a machine are suppressed easily.

Power Supply Voltage 1-phase Input

Servo amplifiers support power supply voltage input of 3-phase 200 V AC and 1-phase 200 V AC. MR-JE-AS servo amplifiers are usable with a wide power supply range.

High Performance



Fast and Accurate

The dedicated engine enables speed frequency response of 2.0 kHz, shortening the cycle time.

High Resolution Encoder

The servo motor is equipped with 131072 pulses/rev (17-bit) high-resolution magnetic encoder, achieving high accuracy.

Energy Conservation

The large capacity main circuit capacitor allows the regenerative energy to be used effectively, reducing energy consumption.

Global Standard



Compliance to Global Standards

Global servo, MR-JE series, complies with global standards as standard.

Sink and Source Connections

Command pulse input and digital input/output are compatible with both sink and source type connections.

Global Support

FA Centers located throughout the world provide attentive services to support users.



Product Lines

Servo amplifier

●: Compatible

Model	Power supply specification	Rated output [kW]	Command interface		Control mode		
			Pulse train	Analog voltage	Position	Speed	Torque
MR-JE-_AS	3-phase 200 V AC 1-phase 200 V AC	0.1, 0.2, 0.4, 0.75, 1, 2	●	●	●	●	●

Servo motor

●: Available

Series	Rated speed [r/min]	Maximum speed [r/min]	Rated output [kW]	With electro-magnetic brake (B)	With oil seal (J)	IP rating *1
HJ-KS series (Low inertia)	3000	5000	0.1, 0.2, 0.4, 0.75, 1, 1.5, 2	●	●	IP65
	2000	3000	1, 1.5, 2	●	●	IP65
HJ-FS series (High inertia)	3000	5000	0.2, 0.4, 0.75, 1	●	●	IP65

*1. The shaft-through portion is excluded.

With Mitsubishi's commitment to total system solutions and global supports, the MELSERVO-JE becomes the answer to the world-wide needs in driving control.

To satisfy your needs of advanced driving control systems, Mitsubishi Electric provides an extensive range of automation products from servo amplifiers and servo motors to programmable controllers, Positioning modules, Human Machine Interfaces and highly developed solutions.

With our global support network which provides attentive services including product purchases, after-sales services, technical consulting, and practical training, we assure you the maximum performance of MELSERVO-JE throughout the world.

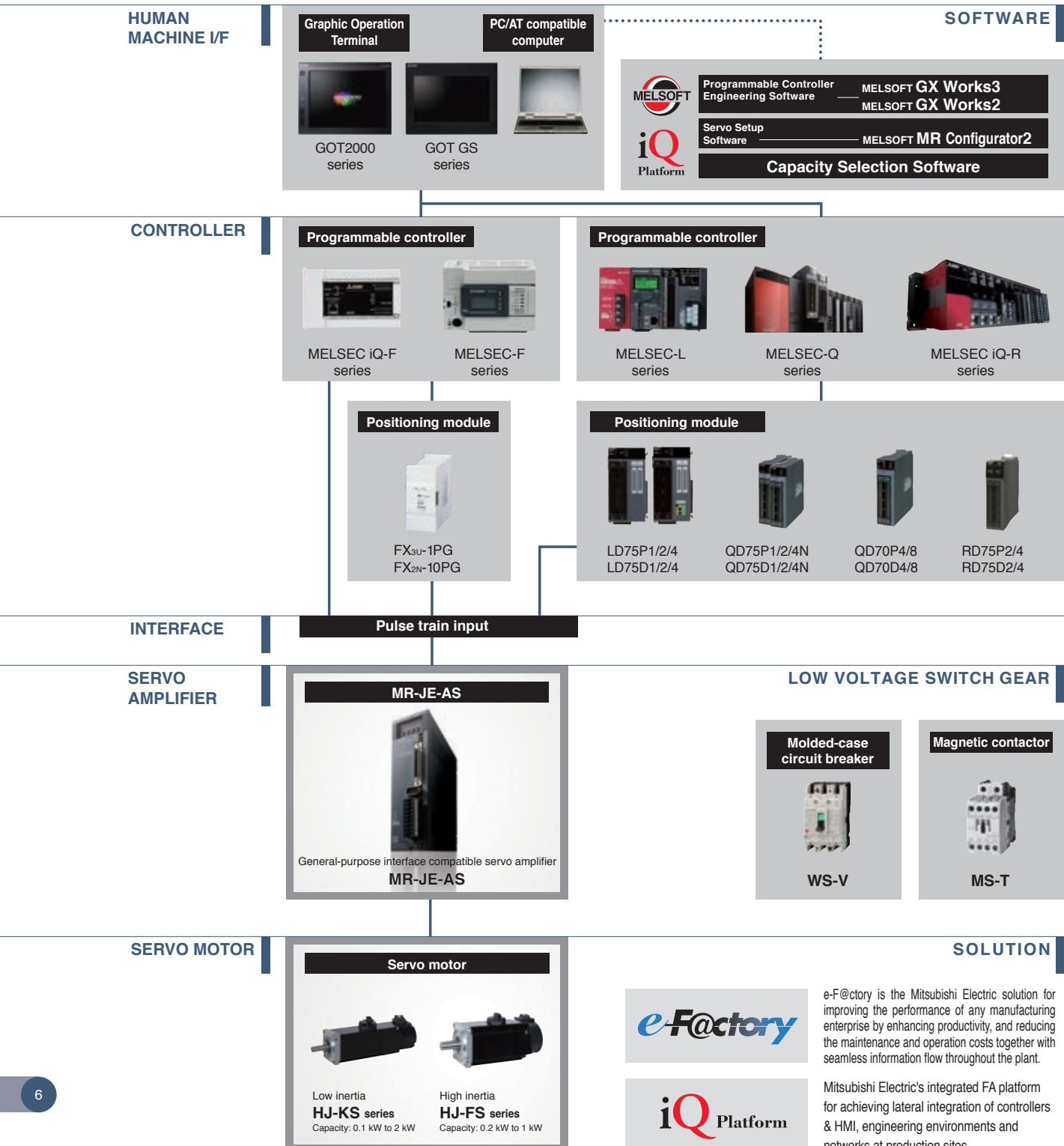

Application Examples

Easy-to-use, yet high performance MR-JE-AS is suitable for various machines.

X-Y table

For X-Y positioning system for machine tools, inspection machines, etc.

- High-performance servo system enables high-speed positioning.
- The 17-bit encoders offer highly accurate positioning.
- The vibration suppression control makes the cycle time shorter.

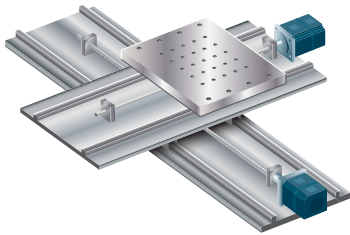

Food processing machines

For food processing, positioning of liquid filling nozzle, unwinding of wrapping material, etc.

- High-performance servo system makes the cycle time shorter.
- The tough drive function increases operating rate of the machine.
- The servo motors are rated IP65*, making it suitable for food processing machines. (* Excluding shaft-through portion)

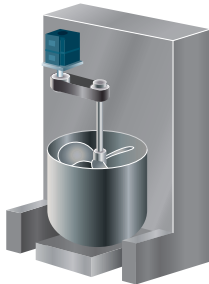

Textile machines

For string unwinding, traversing, etc.

- The small-size servo amplifiers and servo motors enable compact machine designs.
- Servo system enables high-acceleration/deceleration and high-speed conveyance.
- The servo motors are rated IP65*, making it suitable for textile machines. (* Excluding shaft-through portion)

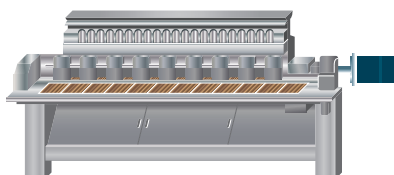

Conveyors

For conveyance between processes of each work, etc.

- Servo system enables high-acceleration/deceleration and high-speed conveyance.
- Stable constant-speed feed
- The auto tuning function makes optimal gain adjustment for various works.

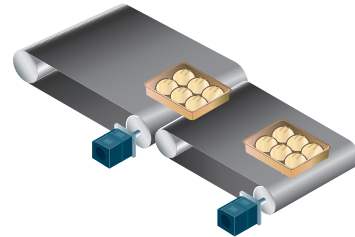

Loaders/unloaders, feeders and sliders

Work positioning and conveyance for automated warehouse, press machines, etc.

- Fast and accurate positioning increases productivity.
- The small-size servo amplifiers and servo motors enable compact machine designs.

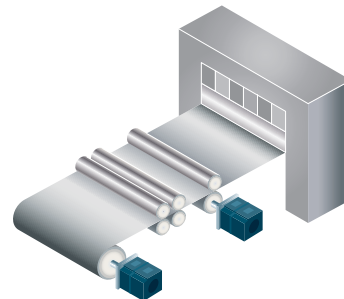

Robots

For picking up and transferring processing work

- The vibration suppression control makes the cycle time shorter.
- The auto tuning function makes optimal gain adjustment for various works.
- The small-size servo amplifiers and servo motors enable compact machine designs.

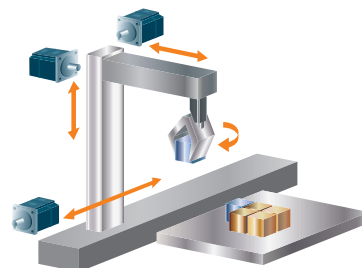

Easy To Use

Fast, Trouble-Free Setup

Mitsubishi Electric's unique "One-touch tuning" enables servo gain adjustment with one-touch ease. The ease of maintenance and the simple setup software would add further usability for all MR-JE-AS users.

High-Precision Tuning

One-Touch Tuning Function

Just turn on the one-touch tuning function to complete servo gain adjustment automatically, including machine resonance filter and advanced vibration suppression control* for maximizing your machine performance.

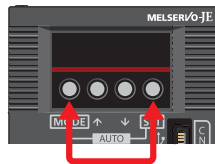

Adjust the servo gains just by pressing the buttons on the front of the servo amplifier.

* Refer to "MR-JE-AS HJ-KS_ HJ-FS_ Instruction Manual" for the advanced vibration suppression control by one-touch adjustment.

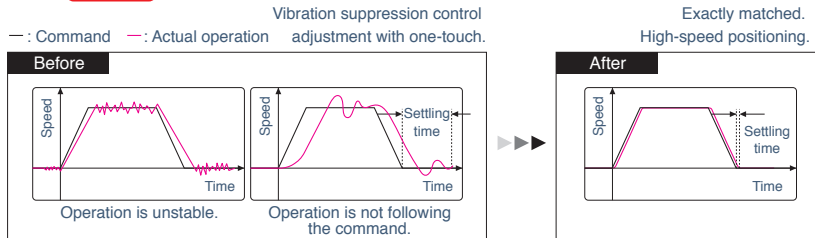

Advanced Vibration Suppression Control

The advanced vibration suppression control suppresses low-frequency vibration, owing to vibration suppression algorithm. Adjustment is easily executed on MR Configurator2. This function is effective in suppressing residual vibration generated at the end of an arm and in a machine, enabling a shorter settling time.

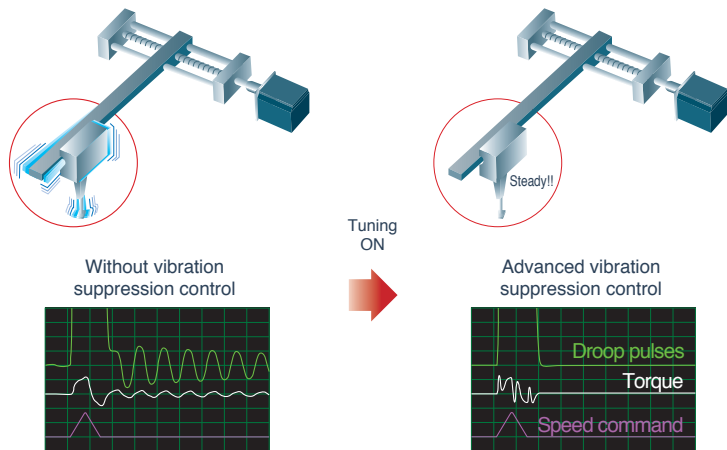

Machine Resonance Suppression Filter

With advanced filter structure, applicable frequency range is expanded to between 10 Hz and 4500 Hz.

Additionally, the number of simultaneously applicable filters is increased to five, improving vibration suppression performance of a machine.

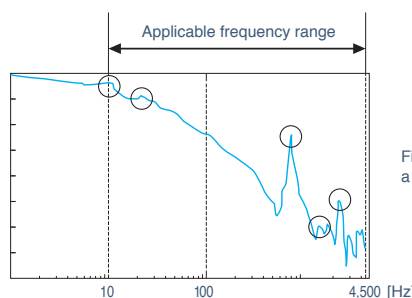

Five filters are settable in a range of 10 Hz to 4500 Hz.

For Changes in Power Supply Environment

Instantaneous Power Failure Tough Drive

When an instantaneous power failure is detected, this function allows the servo amplifier to use the electric energy charged in the main circuit capacitor in the servo amplifier to avoid an alarm occurrence, increasing the operating rate of the machine even with an unstable power supply.

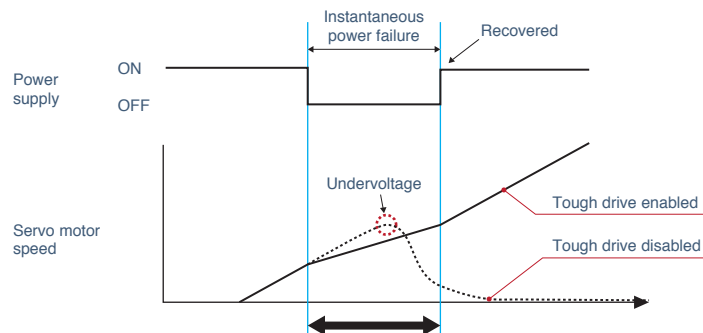

Operation continues even with instantaneous power failure.

Power Supply Voltage Input

Servo amplifiers support power supply voltage input of 3-phase 200 V AC to 240 V AC and 1-phase 200 V AC to 240 V AC.

* When 1-phase 200 V AC to 240 V AC power supply is used with servo amplifiers of 1 kW and 2 kW, use the servo amplifiers with 75% or less of the effective load ratio. The servo amplifiers of 1 kW and 2 kW cannot be mounted closely when 1-phase power is input.

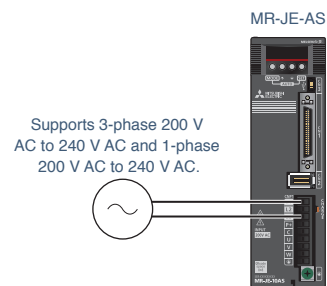

Easy Monitoring and Maintenance

Vibration Tough Drive

Machine resonance suppression filter is automatically readjusted when a change in machine resonance frequency is detected by the servo amplifier. Losses from the machine stop due to age-related deterioration are reduced.



Three-Digit Alarm

MR-JE-AS servo amplifiers display the alarm No. in three digits to show the servo alarm in more details, making troubleshooting easy.

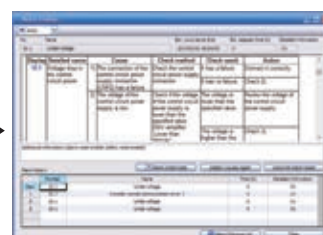

The alarm No. shows whether the undervoltage alarm was caused by instantaneous power failure or by lowered bus voltage in the servo amplifier.

Easy To Use

Monitor Function

The I/O signal status of the servo amplifier is displayed on the [I/O monitor] window of MR Configurator2. This function can be used as troubleshooting at alarm occurrence in addition to the wiring check at machine assembling. Additionally, the operation status is monitored on the [Display all] window. The effective load ratio and regenerative load ratio of the servo motor are monitored.

[I/O monitor] window

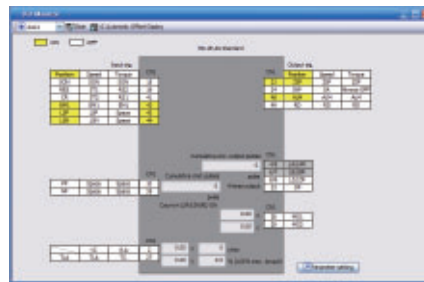

Servo Amplifier Life Diagnosis Function

Cumulative operation time and on/off times of the inrush relay can be checked with MR Configurator2. This function provides an indication of replacement time for servo amplifier parts such as capacitor and relays.

[Life diagnosis] window

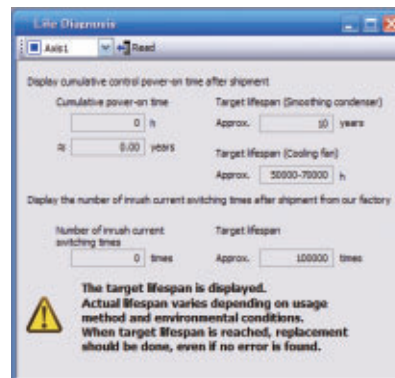

User-Friendly Motors

Servo Motors with Low and High Inertia

Select from two type of the servo motors according to the moment of inertia of the driving parts and the operation patterns.
HJ-KS series: low inertia, suitable for high-speed and high-throughput operation
HJ-FS series: high inertia for higher driving stability

Improved Environment Safety

HJ-KS series and HJ-FS series are rated IP65*.

* The shaft-through portion is excluded.

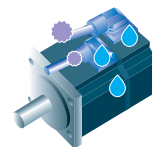

Protected from water and dust.

Selectable Cable Leading Direction

Cables for power, encoder, and electromagnetic brake are capable of connecting either in direction or in opposite direction of the load side, depending on the cable selection.

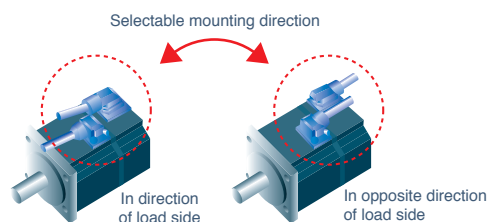

MR Configurator2

(SW1DNC-MRC2-E)

The easy-to-use design MR-JE series makes startup and adjustment that simple.

Tuning, monitor display, diagnosis, reading/writing parameters, and test operations are easily performed on a personal computer. This powerful software tool supports a stable machine system and optimum control, and moreover, shortens setup time.



Preparation

Servo Assistant Function

Complete setting up the servo amplifier just by following guidance displays. Related functions are called up from the shortcut buttons, making it so easy to set parameters and display alarms.



Setting

Parameter Setting Function

Display parameter setting in list or visual formats, and set parameters by selecting from the drop down list.



Startup

Graph Function

The number of measurement channels is increased to 7 channels for analog and 8 channels for digital. Display various servo statuses in the waveform at one measurement, supporting setting and adjustment. Convenient functions such as [Overwrite] for overwriting multiple data and [Graph history] for displaying graph history are available.

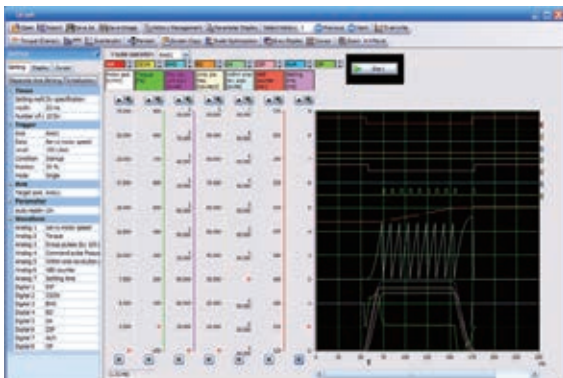

Maintenance

Alarm Display

Check the alarm No., data of the servo amplifier at alarm occurrence, estimated generation time, and alarm history.

Alarm No.	Alarm Name	Cause	Check Method	Check Result	Action
10.1	Voltage drop in the control circuit power	1) The connection of the control circuit power supply connector (CN2) has a failure. 2) The voltage of the control circuit power supply is low.	Check the control circuit power supply connection. Check if the voltage of the control circuit power supply is lower than the specified value (24V) or higher than the specified value.	It has a failure. It has no failure.	Connect it correctly. Check 2). Remove the voltage of the control circuit power supply.

High Performance

Further Reduction of Cycle Time

Top-level basic performance is achieved, including speed frequency response of 2.0 kHz. The MR-JE-AS servo amplifiers that utilizes regenerative energy maximizes the machine performance and energy saving.

Fast and Accurate

2.0 kHz Speed Frequency Response

The top-level speed frequency response of 2.0 kHz shortens the settling time substantially, reducing the cycle time of a machine.

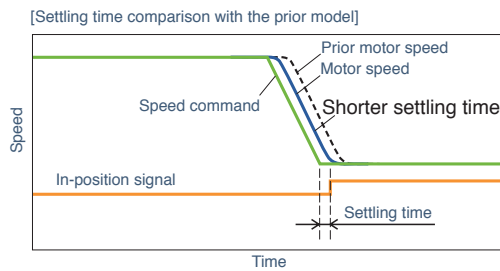

High-Resolution Encoder

The servo motor equipped with a high-resolution magnetic encoder of 131072 pulses/rev (17-bit) enables high-accuracy positioning and smooth rotation.

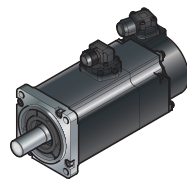

Equipped with 17-bit high-resolution incremental encoder.

Maximum Command Pulse Frequency of 4 Mpulses/s

MR-JE-AS having a general-purpose interface is compatible with the maximum command pulse frequency of 4 Mpulses/s, enabling smooth operation.

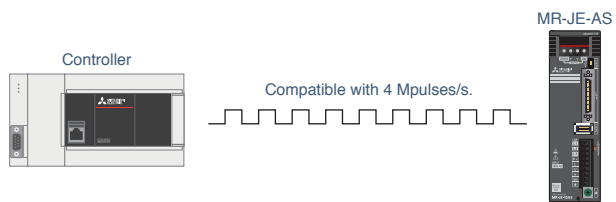

Position Control/Speed Control/Torque Control

The command interface of MR-JE-AS servo amplifier is compatible with both pulse train command and analog voltage command. The MR-JE-AS enables position control with pulse train command, and speed and torque control with analog voltage command.

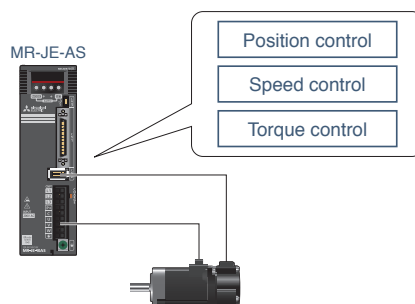

Eco-Friendly Performance

Efficient Utilization of Regenerative Energy

The MR-JE-AS servo amplifier has a main circuit capacitor with large capacity, utilizing regenerative energy as power running energy for reuse. Additionally, the control circuit and the main circuit use a common power supply, allowing the regenerative energy to be used for the control circuit, which reduces waste in energy consumption.

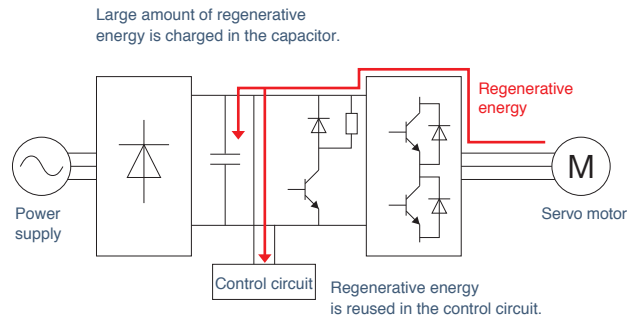

Power Monitor

Power running and regenerative energy are calculated from the data in the servo amplifier such as speed and current, and the power consumption is monitored with MR Configurator2. Visualization of the power consumption helps to save energy.

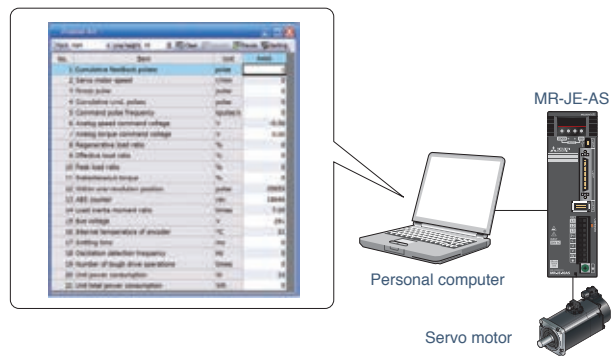

Saving Energy with Advanced Technologies

Reduced energy loss of the servo amplifier

Efficiency is increased by the use of a new power module. Energy loss of the servo amplifier itself is reduced.

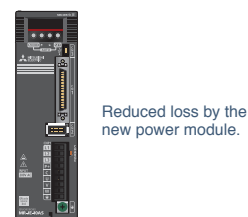

Saving energy by improving machine performance

MR-JE-AS servo amplifiers and HJ-KS/HJ-FS servo motors with the industry-leading level of high performance reduce machine cycle time and operation time, resulting less energy consumption.

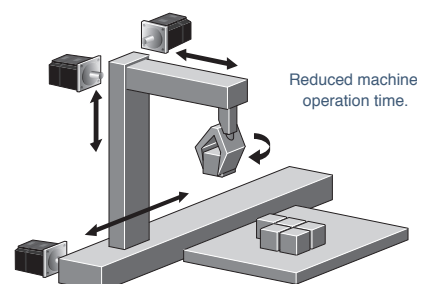

Global Standard

Fully Compliant Worldwide

To satisfy growing needs in driving control throughout the world, the MR-JE-AS complies with global standards. Command pulse input and digital input/output are compatible with both sink and source type connections.

Global Servo Meets Global Standards

Conformity with Global Standards and Regulations

Use the MR-JE-AS globally. The servo amplifiers and the servo motors conform to global standards as standard.



Global standards and regulations *2		Servo amplifier	Servo motor
European EC directive	Low voltage directive	EN 61800-5-1	EN 60034-1
	EMC directive *1	EN 61800-3	EN 61800-3
	RoHS directive	Compliant	Compliant
UL standard		UL 508C	-
CSA standard		CSA C22.2 No. 14	-
Measures for Administration of the Pollution Control of Electronic Information Products (Chinese RoHS)		Compliant (optional cables and connectors)	Compliant (optional cables and connectors)
China Compulsory Certification (CCC)		N/A	N/A
Korea Radio Wave Law (KC)		Compliant	-
Certification system of the Eurasian Economic Union (EAC)		Compliant	-

*1. Refer to relevant Servo Amplifier Instruction Manual and "EMC Installation Guidelines" when your system needs to meet the EMC directive.
 *2. When exporting the product, follow the local laws and regulations.

Sink and Source Connections

Command pulse input and digital input/output are compatible with both sink and source type connections.

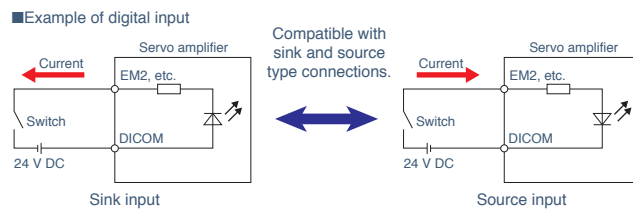

Extensive Global Support Network

Global FA Centers

Across the globe, FA Centers provide customers with local assistance for purchasing Mitsubishi Electric products and with after-sales services. To enable national branch offices and local representatives to work together in responding to local needs, we have developed a service network throughout the world. We provide repairs, on-site engineering support, and sales of replacement parts. We also provide various services from technical consulting services by our expert engineers to practical training for equipment operations.

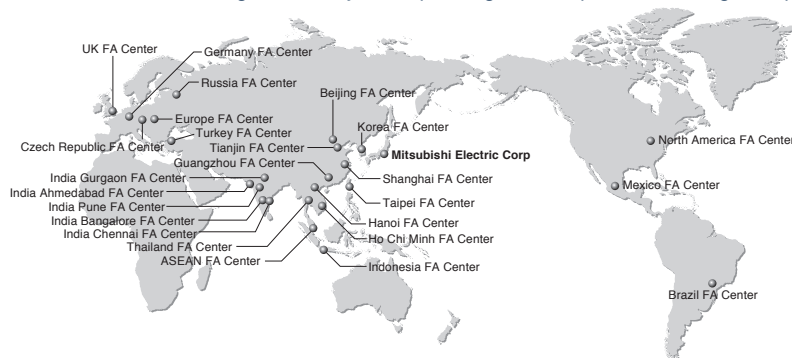

1

Servo Amplifiers

Model Designation.....	1-2
Combinations of Servo Amplifier and Servo Motor.....	1-2
MR-JE-AS	
Connections with Peripheral Equipment.....	1-3
Specifications	1-4
Standard Wiring Diagram Example	1-5
RS-422 Serial Communication Connection Example.....	1-9
Power Supply Connection Example	1-10
1-phase 200 V AC Class Power Supply Input Using a Neutral Point of 3-phase 400 V AC Class Power Supply	1-11
Servo Motor Connection Example.....	1-12
Dimensions.....	1-13

Servo Amplifiers

Model Designation for Servo Amplifier

MR-JE-10AS

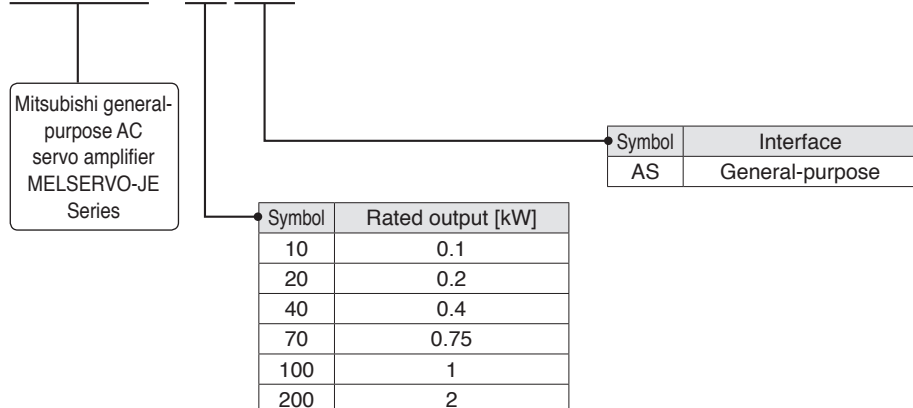

Combinations of Servo Amplifier and Servo Motor

Servo Amplifiers	Servo motor	
	HJ-KS series	HJ-FS series
MR-JE-10AS	HJ-KS13	-
MR-JE-20AS	HJ-KS23	HJ-FS23
MR-JE-40AS	HJ-KS43	HJ-FS43
MR-JE-70AS	HJ-KS73	HJ-FS73
MR-JE-100AS	HJ-KS103A HJ-KS103 HJ-KS102	HJ-FS103A
MR-JE-200AS	HJ-KS153 HJ-KS203 HJ-KS152 HJ-KS202	-

MR-JE-AS Connections with Peripheral Equipment (Note 1)

Peripheral equipment is connected to MR-JE-AS as described below. Connectors, cables, options, and other necessary equipment are available so that users can set up the servo amplifier easily and start using it right away.

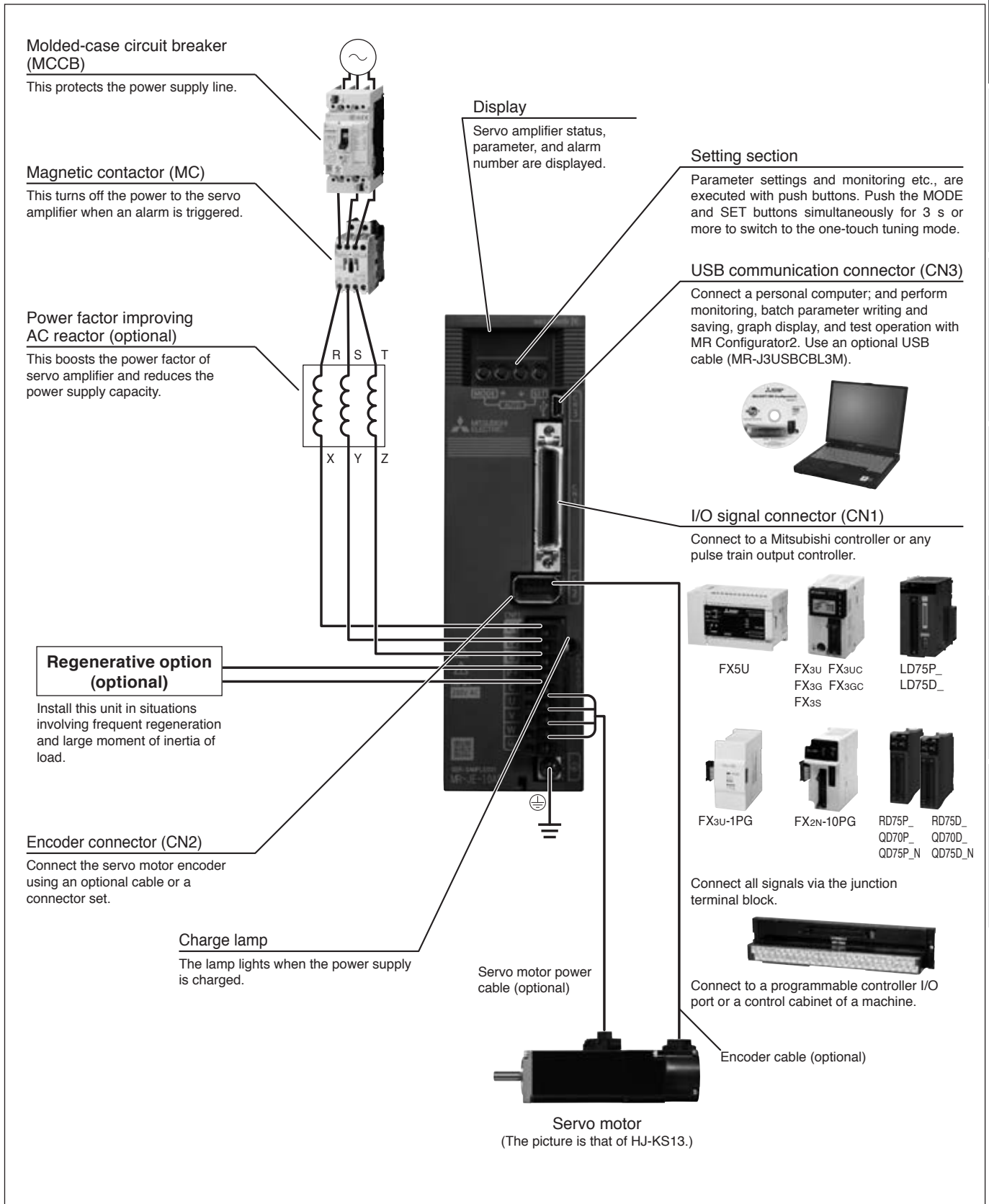

Notes: 1. The connection with the peripheral equipment is an example for MR-JE-100AS or smaller servo amplifiers. Refer to "MR-JE-AS HJ-KS_ HJ-FS_ Instruction Manual" for the actual connections.

Servo Amplifiers

MR-JE-AS (General-purpose Interface) Specifications

Servo amplifier model MR-JE-		10AS	20AS	40AS	70AS	100AS	200AS
Output	Rated voltage	3-phase 170 V AC					
	Rated current [A]	1.1	1.5	2.8	5.8	6.0	11.0
Power supply input	Voltage/frequency (Note 1)	3-phase or 1-phase 200 V AC to 240 V AC, 50 Hz/60 Hz				3-phase or 1-phase 200 V AC to 240 V AC, 50 Hz/60 Hz (Note 7)	
	Rated current (Note 6) [A]	0.9	1.5	2.6	3.8	5.0	10.5
	Permissible voltage fluctuation	3-phase or 1-phase 170 V AC to 264 V AC				3-phase or 1-phase 170 V AC to 264 V AC (Note 7)	
	Permissible frequency fluctuation	±5% maximum					
Interface power supply		24 V DC ± 10% (required current capacity: 0.3 A)					
Control method		Sine-wave PWM control/current control method					
Permissible regenerative power of the built-in regenerative resistor (Note 2, 3) [W]		-	-	10	20	20	100
Dynamic brake (Note 4)		Built-in					
Communication function		USB: Connect a personal computer (MR Configurator2 compatible) RS-422: Connect a controller (1 : n communication (up to 32 axes))					
Encoder output pulse		Compatible (A/B/Z-phase pulse)					
Analog monitor		2 channels					
Position control mode	Maximum input pulse frequency	4 Mpulses/s (when using differential receiver), 200 kpulses/s (when using open collector)					
	Positioning feedback pulse	Encoder resolution: 131072 pulses/rev					
	Command pulse multiplying factor	Electronic gear A/B multiple, A: 1 to 16777215, B: 1 to 16777215, 1/10 < A/B < 4000					
	Positioning complete width setting	0 pulse to ±65535 pulses (command pulse unit)					
	Error excessive	±3 rotations					
Torque limit		Set by parameters or external analog input (0 V DC to +10 V DC/maximum torque)					
Speed control mode	Speed control range	Analog speed command 1:2000, internal speed command 1:5000					
	Analog speed command input	0 V DC to ±10 V DC/rated speed (Speed at 10 V is changeable with [Pr. PC12].)					
	Speed fluctuation rate	±0.01% maximum (load fluctuation 0% to 100%), 0% (power fluctuation: ±10%) ±0.2% maximum (ambient temperature: 25 °C ± 10 °C) only when using analog speed command					
	Torque limit	Set by parameters or external analog input (0 V DC to +10 V DC/maximum torque)					
Torque control mode	Analog torque command input	0 V DC to ±8 V DC/maximum torque (input impedance: 10 kΩ to 12 kΩ)					
	Speed limit	Set by parameters or external analog input (0 V DC to ± 10 V DC/rated speed)					
Servo functions		Advanced vibration suppression control, adaptive filter II, auto tuning, one-touch tuning, tough drive function, power monitoring function					
Protective functions		Overcurrent shut-off, regenerative overvoltage shut-off, overload shut-off (electronic thermal), servo motor overheat protection, encoder error protection, regenerative error protection, undervoltage protection, instantaneous power failure protection, overspeed protection, error excessive protection					
Compliance to global standards		Refer to "Conformity with Global Standards and Regulations" on p. 14 in this catalog.					
Structure (IP rating)		Natural cooling, open (IP20)					Force cooling, open (IP20)
Close mounting (Note 5)	3-phase power supply input	Possible					
	1-phase power supply input	Possible				Not possible	
Environment	Ambient temperature	Operation: 0 °C to 55 °C (non-freezing), storage: -20 °C to 65 °C (non-freezing)					
	Ambient humidity	Operation/storage: 5 %RH to 90 %RH (non-condensing)					
	Ambience	Indoors (no direct sunlight); no corrosive gas, inflammable gas, oil mist or dust					
	Altitude	1000 m or less above sea level					
Vibration resistance		5.9 m/s ² at 10 Hz to 55 Hz (directions of X, Y and Z axes)					
Mass [kg]		0.8	0.8	0.8	1.5	1.5	2.1

Notes: 1. Rated output and speed of a servo motor are applicable when the servo amplifier, combined with the servo motor, is operated within the specified power supply voltage and frequency.

2. Select the most suitable regenerative option for your system with our capacity selection software.

3. Refer to "Regenerative Option" in this catalog for the permissible regenerative power [W] when regenerative option is used.

4. When using the dynamic brake, refer to "MR-JE-AS HJ-KS_ HJ-FS_ Instruction Manual" for the permissible load to motor inertia ratio.

5. When the servo amplifiers are closely mounted, keep the ambient temperature within 0 °C to 45 °C, or use the servo amplifiers with 75% or less of the effective load ratio.

6. This value is applicable when a 3-phase power supply is used.

7. When a 1-phase 200 V AC to 240 V AC power supply is used, use the servo amplifiers with 75% or less of the effective load ratio.

MR-JE-AS Standard Wiring Diagram Example: Position Control Operation

Connecting to FX5U (position servo, incremental)

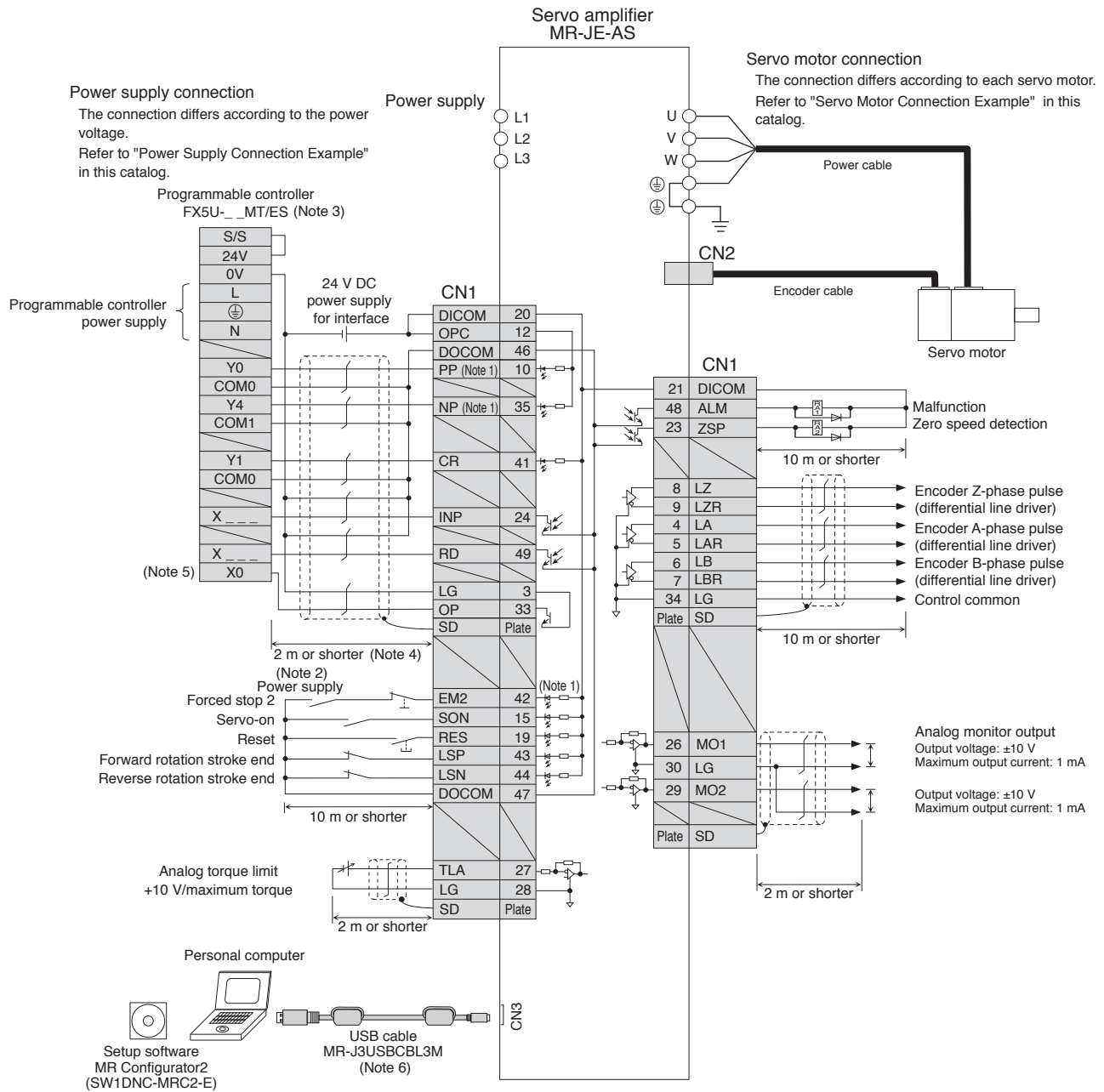

! Be sure to read through Instruction Manual for the actual wiring and use. Use the equipment after you have a full knowledge of the equipment, safety information and instructions.

Servo Amplifiers
Servo Motors
Options/Peripheral Equipment
LVS/Wires
Product List
Cautions

Servo Amplifiers

MR-JE-AS Standard Wiring Diagram Example: Position Control Operation

Connecting to QD75D/LD75D/RD75 (position servo, incremental)

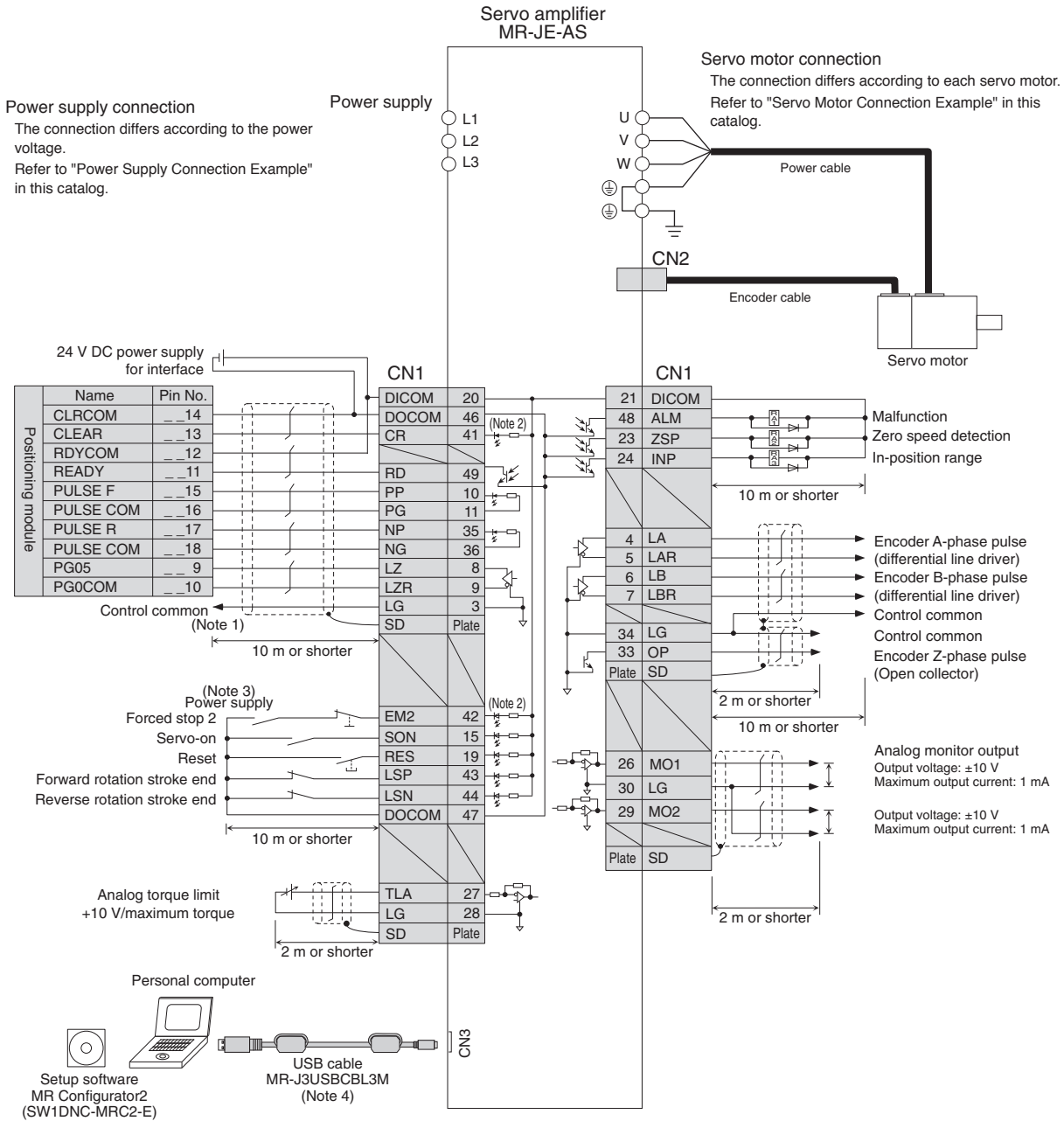

- Notes: 1. This connection is not necessary for QD75D/LD75D/RD75 Positioning module. Note that the connection between LG and control common terminal is recommended for some Positioning modules to improve noise tolerance.
 2. This is for sink wiring. Source wiring is also possible.
 3. To prevent an unexpected restart of the servo amplifier, create a circuit to turn off EM2 (Forced stop 2) when the power is turned off.
 4. USB and RS-422 communication functions are mutually exclusive. Do not use them at the same time.



Be sure to read through Instruction Manual for the actual wiring and use. Use the equipment after you have a full knowledge of the equipment, safety information and instructions.

MR-JE-AS Standard Wiring Diagram Example: Speed Control Operation

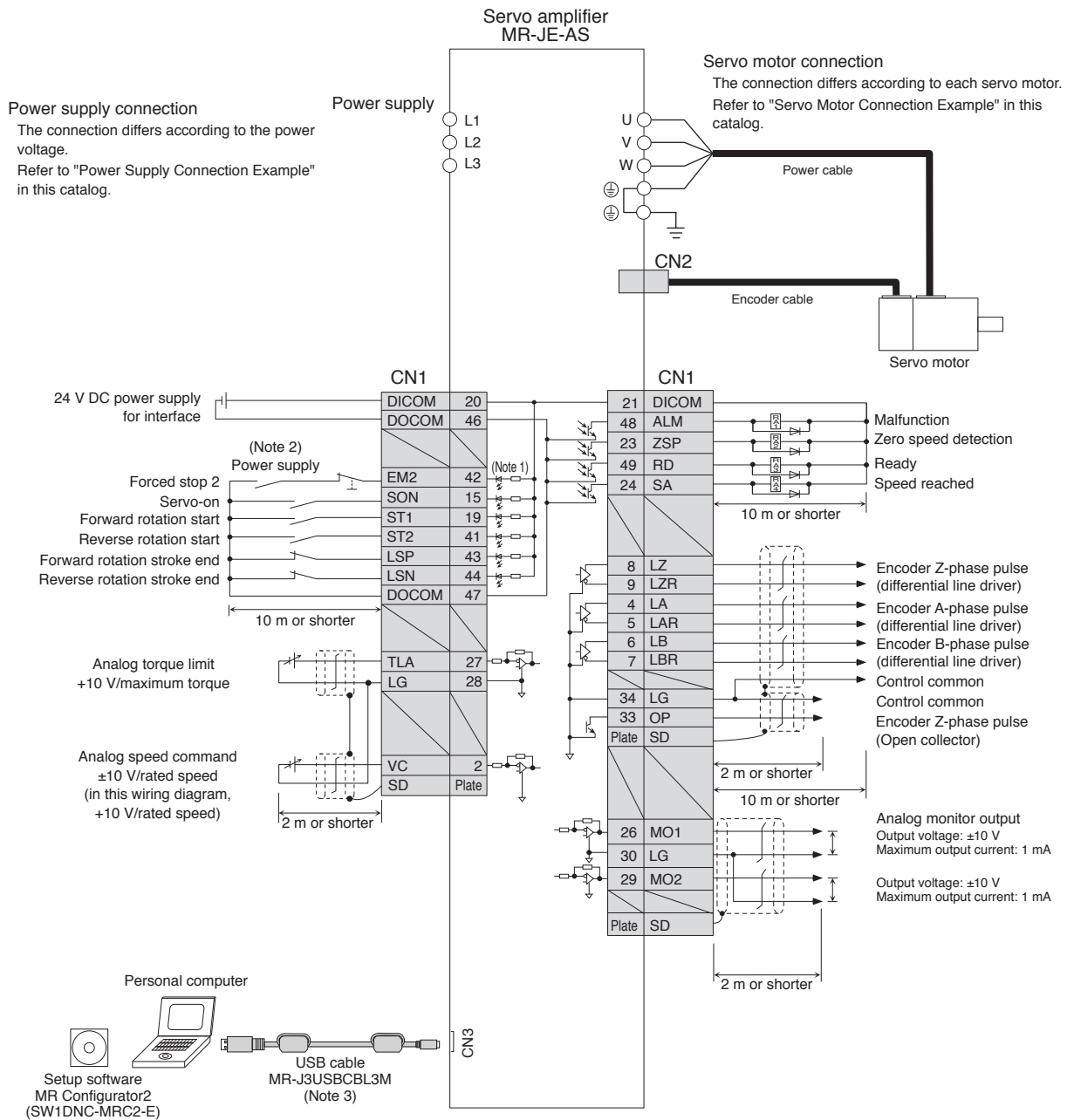

- Notes: 1. This is for sink wiring. Source wiring is also possible.
2. To prevent an unexpected restart of the servo amplifier, create a circuit to turn off EM2 (Forced stop 2) when the power is turned off.
3. USB and RS-422 communication functions are mutually exclusive. Do not use them at the same time.



Be sure to read through Instruction Manual for the actual wiring and use. Use the equipment after you have a full knowledge of the equipment, safety information and instructions.

Servo Amplifiers

MR-JE-AS Standard Wiring Diagram Example: Torque Control Operation

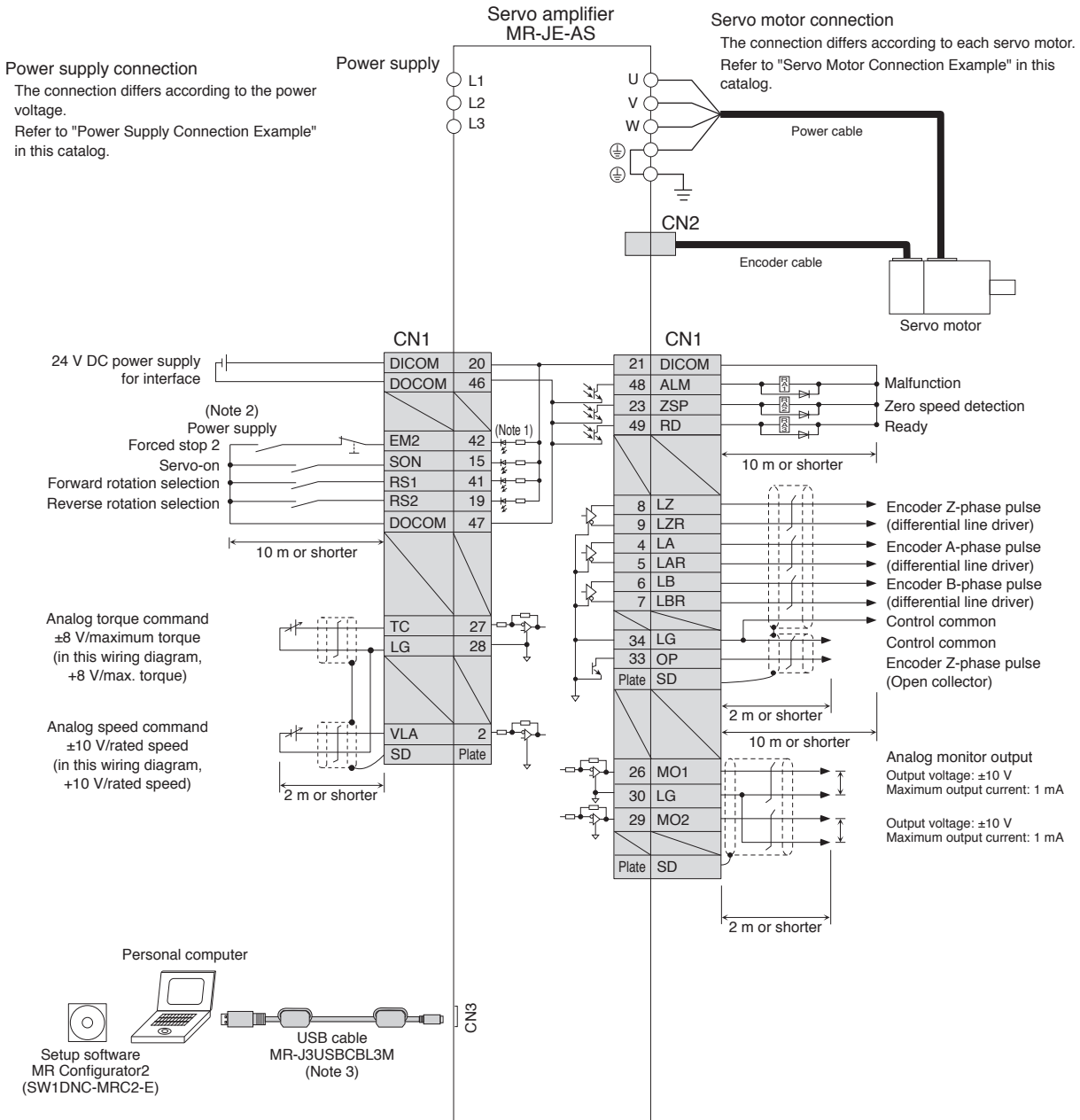

- Notes: 1. This is for sink wiring. Source wiring is also possible.
 2. To prevent an unexpected restart of the servo amplifier, create a circuit to turn off EM2 (Forced stop 2) when the power is turned off.
 3. USB and RS-422 communication functions are mutually exclusive. Do not use them at the same time.

⚠ Be sure to read through Instruction Manual for the actual wiring and use. Use the equipment after you have a full knowledge of the equipment, safety information and instructions.

RS-422 Serial Communication Connection Example

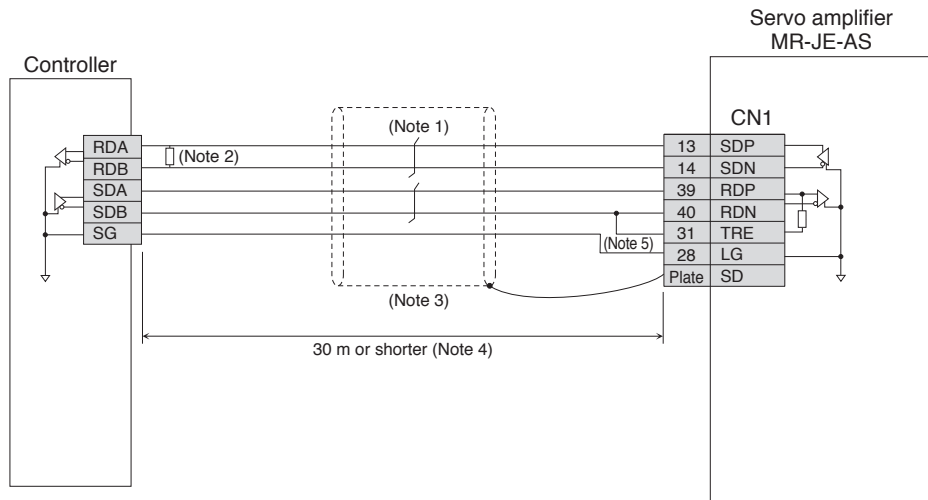

- Notes: 1. Twist the wires from SDP and SDN together, and RDP and PDN together.
 2. Refer to the controller manual to connect a termination resistor. If a termination resistor is not specified, terminate with a 150 Ω resistor.
 3. It is recommended that the cable be shielded.
 4. The cable length must be 30 m or shorter in a low-noise environment. When connecting multiple axes, also keep the overall length within 30 m.
 5. Connect TRE and RDN for the servo amplifier of the final axis.

 Be sure to read through Instruction Manual for the actual wiring and use. Use the equipment after you have a full knowledge of the equipment, safety information and instructions.

Servo Amplifiers

Servo Motors

Options/Peripheral Equipment

LVS/Wires

Product List

Cautions

Servo Amplifiers

Power Supply Connection Example (MR-JE-AS)

● For 1-phase 200 V AC, 1 kW or smaller

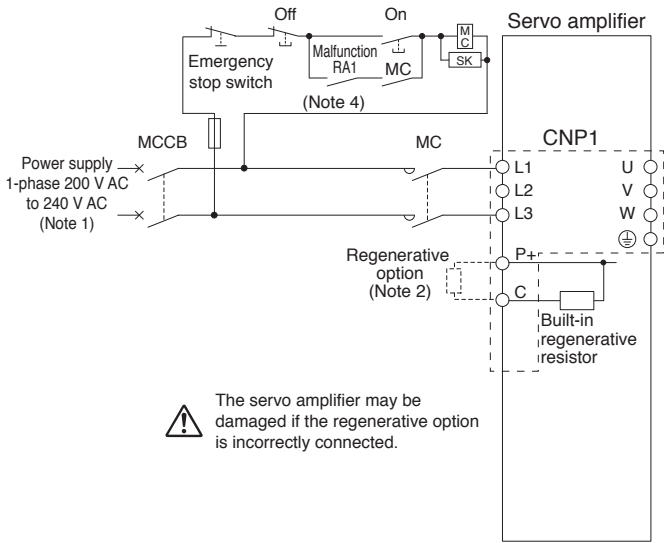

● For 3-phase 200 V AC, 1 kW or smaller

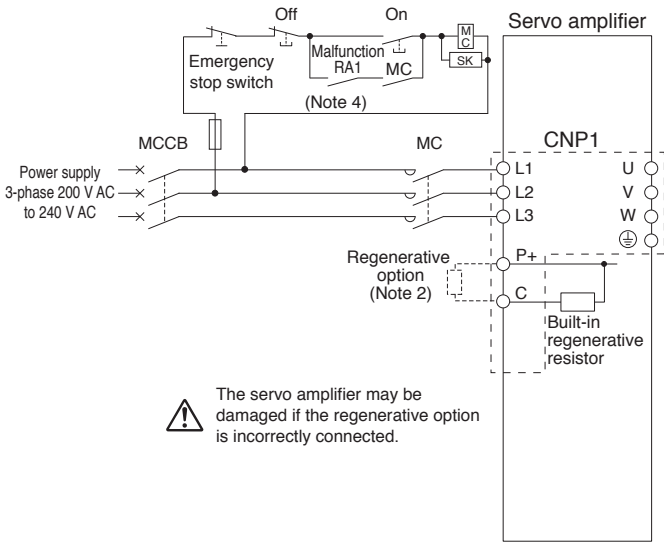

● For 1-phase 200 V AC, 2 kW

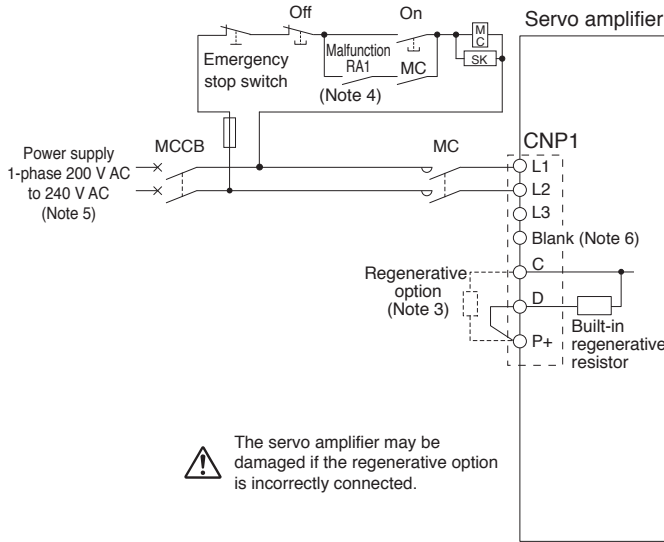

● For 3-phase 200 V AC, 2 kW

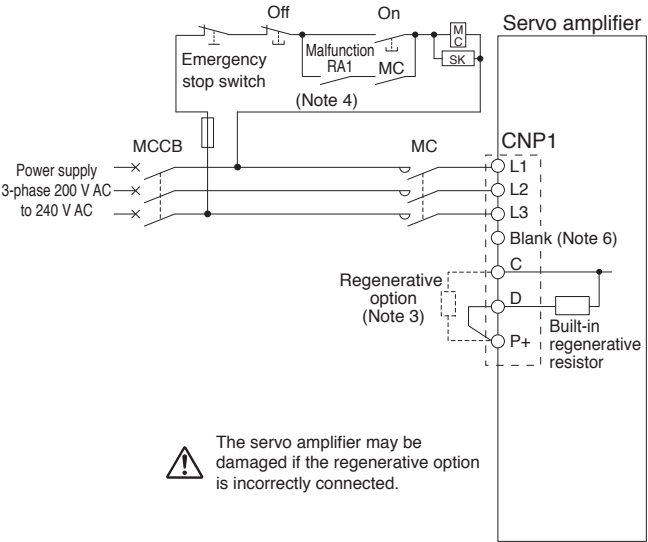

- Notes: 1. For 1-phase 200 V AC to 240 V AC, connect the power supply to L1 and L3 terminals. Do not connect anything to L2. The connections are different from MR-E Super series servo amplifiers.
 2. Disconnect the wires for the built-in regenerative resistor (P+ and C), and the regenerative resistor when connecting the regenerative option externally.
 3. Disconnect a short-circuit bar between P+ and D when connecting the regenerative option externally.
 4. Create a power circuit to turn off the magnetic contactor when ALM (Malfunction) is off (alarm occurrence).
 5. For 1-phase 200 V AC to 240 V AC, connect the power supply to L1 and L2 terminals. Do not connect anything to L3.
 6. N- will be removed sequentially from December 2016.



Be sure to read through Instruction Manual for the actual wiring and use. Use the equipment after you have a full knowledge of the equipment, safety information and instructions.

1-phase 200 V AC Class Power Supply Input Using a Neutral Point of 3-phase 400 V AC Class Power Supply

A 1-phase 200 V AC class power can be supplied with a use of a neutral point of a 3-phase 400 V AC class power supply. Use a step-down transformer as necessary to keep the power supply voltage between 200 V AC and 240 V AC.

 Do not input a 3-phase 400 V AC class power supply directly to the 200 V class servo amplifier. Doing so may cause the servo amplifier to malfunction.

● For MR-JE-10AS to MR-JE-100AS

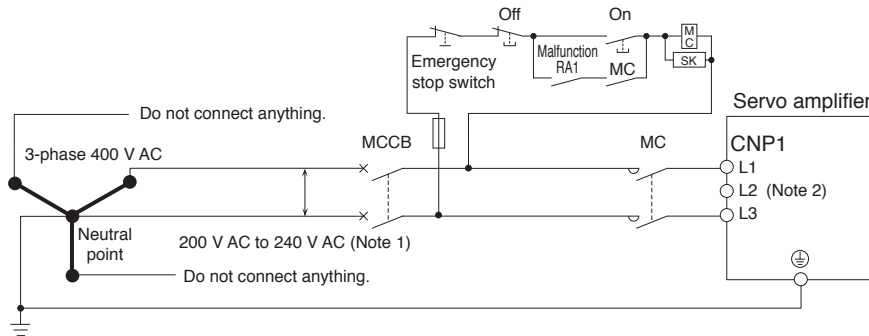

● For MR-JE-200AS

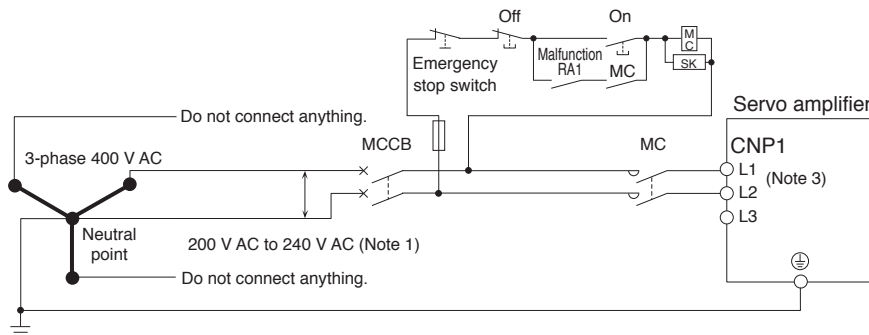

- Notes: 1. Use a step-down transformer as necessary to keep the power supply voltage between 200 V AC and 240 V AC.
 2. For 1-phase 200 V AC to 240 V AC, connect the power supply to L1 and L3 terminals. Do not connect anything to L2.
 3. For 1-phase 200 V AC to 240 V AC, connect the power supply to L1 and L2 terminals. Do not connect anything to L3.

 Be sure to read through Instruction Manual for the actual wiring and use. Use the equipment after you have a full knowledge of the equipment, safety information and instructions.

Servo Amplifiers
 Servo Motors
 Options/Peripheral Equipment
 LVS/Wires
 Product List
 Cautions

Servo Amplifiers

Servo Motor Connection Example

● For HJ-KS/HJ-FS series

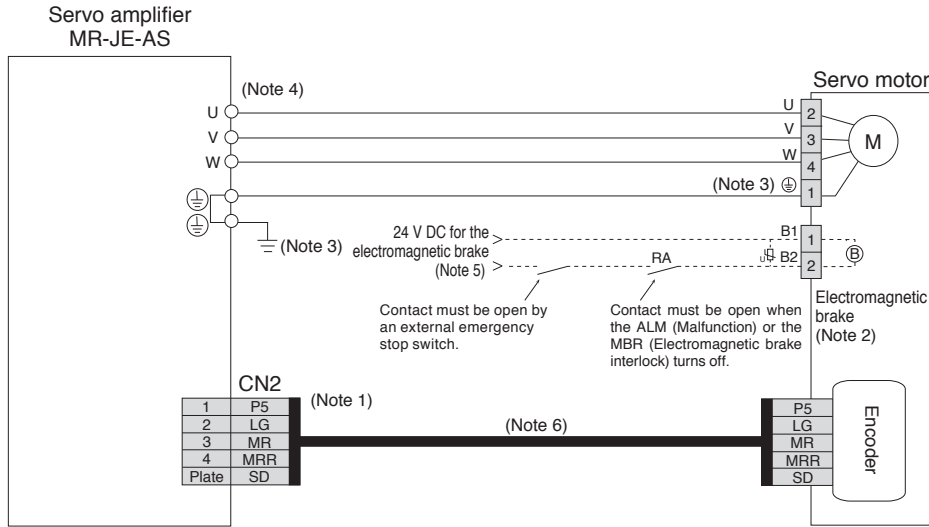

Notes: 1. The signals shown are applicable when a two-wire type encoder cable is used.

2. This is for the servo motor with electromagnetic brake. The electromagnetic brake terminals (B1, B2) do not have polarity.

3. For 1 kW or smaller servo amplifiers, connect the grounding terminal of the servo motor to the cabinet protective earth (PE) terminal (⊕) located on the lower front of the servo amplifier to the cabinet protective earth (PE).

For 2 kW servo amplifiers, connect the grounding terminal of the servo motor to the protective earth (PE) terminal (⊕) located on the lower front of the servo amplifier, and connect the other protective earth (PE) terminal (⊕) to the cabinet protective earth (PE).

4. The connector varies depending on the servo amplifier capacities. Refer to the dimensions of the relevant servo amplifier in this catalog for details.

5. Do not use the 24 V DC interface power supply for the electromagnetic brake. Provide a dedicated power supply to the electromagnetic brake.

6. Encoder cable is available as an option. Refer to "MR-JE-AS HJ-KS_ HJ-FS_ Instruction Manual" when fabricating the cables.



Be sure to read through Instruction Manual for the actual wiring and use. Use the equipment after you have a full knowledge of the equipment, safety information and instructions.

MR-JE-AS Dimensions

- MR-JE-10AS (Note 1)
- MR-JE-20AS (Note 1)
- MR-JE-40AS (Note 1)

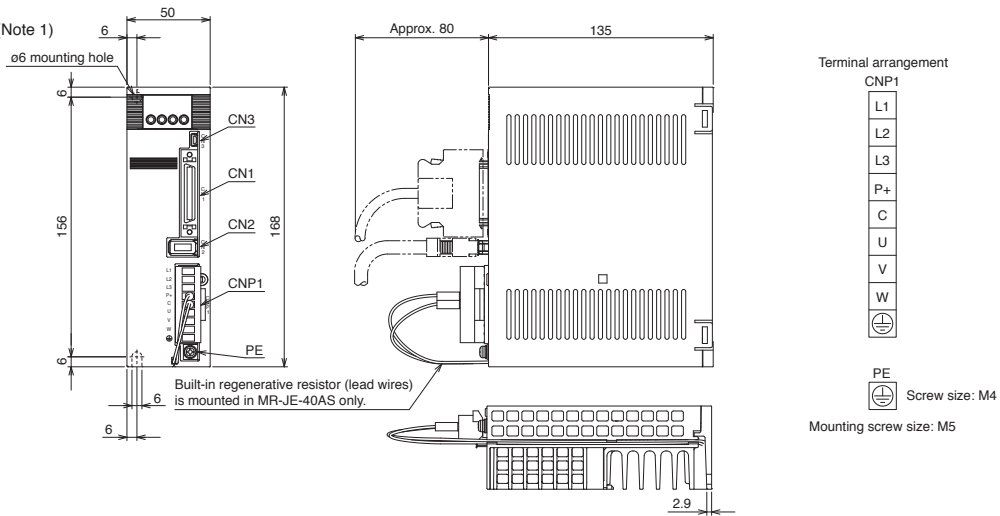

[Unit: mm]

- MR-JE-70AS (Note 1)
- MR-JE-100AS (Note 1)

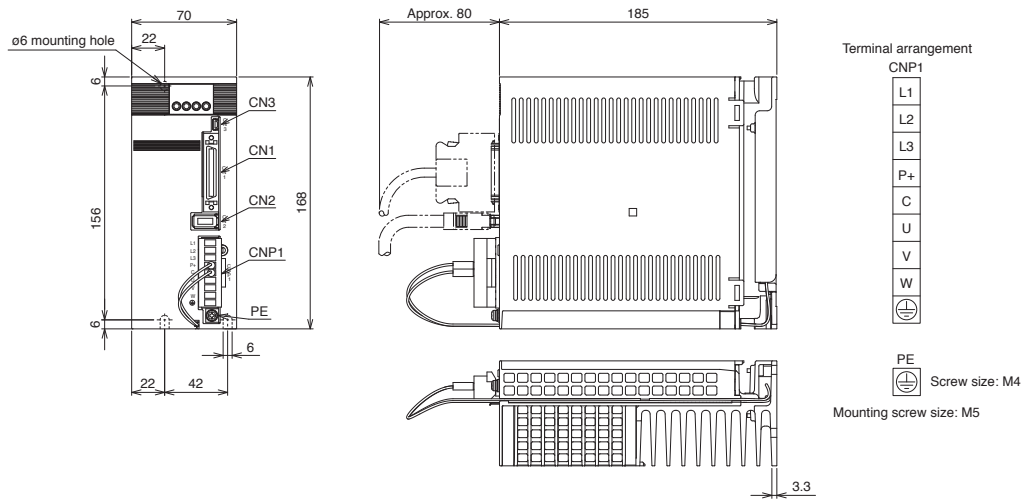

[Unit: mm]

- MR-JE-200AS (Note 2)

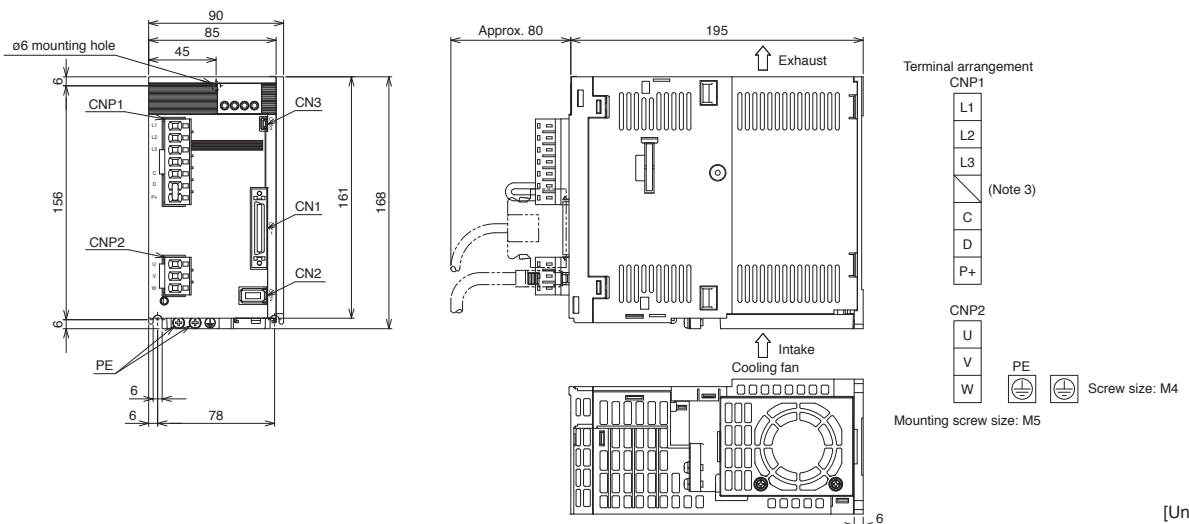

[Unit: mm]

Notes: 1. CNP1 connector (insertion type) is supplied with the servo amplifier.
 2. CNP1 and CNP2 connectors (insertion type) are supplied with the servo amplifier.
 3. N- will be removed sequentially from December 2016.

MEMO



2

Servo Motors

Model Designation.....	2-2
Combinations of Servo Motor and Servo Amplifier.....	2-2
Specifications	
HJ-KS series.....	2-3
HJ-FS series.....	2-7
Dimensions	
HJ-KS/HJ-FS series	2-10
Sizing Example.....	2-12

Servo Motors

Model Designation

H J - K S 1 0 3 B J

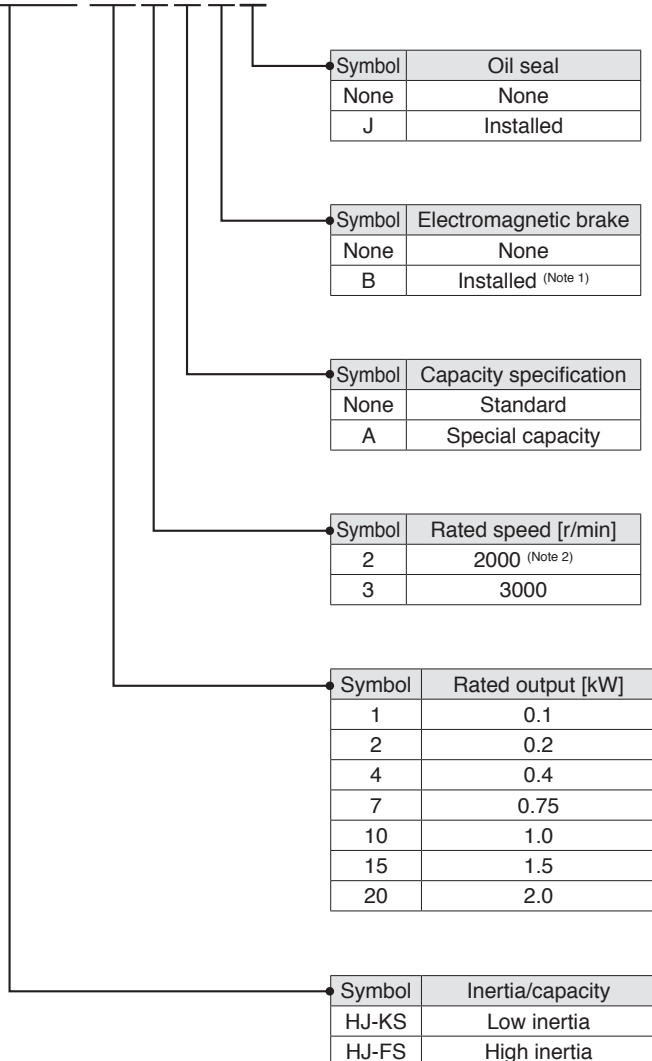

Notes: 1. Refer to electromagnetic brake specifications of each servo motor series in this catalog for the available models and detailed specifications.
 2. 2000 r/min is for 1.0 kW to 2.0 kW of HJ-KS series only.

Combinations of Servo Motor and Servo Amplifier

	Servo Motors	Servo amplifier
HJ-KS 3000 r/min series	HJ-KS13	MR-JE-10AS
	HJ-KS23	MR-JE-20AS
	HJ-KS43	MR-JE-40AS
	HJ-KS73	MR-JE-70AS
	HJ-KS103A	MR-JE-100AS
	HJ-KS103	MR-JE-100AS
	HJ-KS153	MR-JE-200AS
HJ-KS 2000 r/min series	HJ-KS203	MR-JE-200AS
	HJ-KS102	MR-JE-100AS
	HJ-KS152	MR-JE-200AS
HJ-FS series	HJ-KS202	MR-JE-200AS
	HJ-FS23	MR-JE-20AS
	HJ-FS43	MR-JE-40AS
	HJ-FS73	MR-JE-70AS
	HJ-FS103A	MR-JE-100AS

HJ-KS 3000 r/min Series (Low Inertia) Specifications

Servo motor model		HJ-KS	13(B)	23(B)	43(B)	73(B)	103A(B)	103(B)	153(B)	203(B)	
Compatible servo amplifier model		Refer to "Combinations of Servo Motor and Servo Amplifier" on p. 2-2 in this catalog.									
Power supply capacity ^{*1}		[kVA]	0.3	0.5	0.9	1.3	1.7	1.7	2.5	3.5	
Continuous running duty	Rated output	[kW]	0.1	0.2	0.4	0.75	1.0	1.0	1.5	2.0	
	Rated torque (Note 3)	[N·m]	0.32	0.64	1.3	2.4	3.2	3.2	4.8	6.4	
Maximum torque		[N·m]	0.95	1.9	3.8	7.2	9.5	9.5	14.3	19.1	
Rated speed		[r/min]	3000								
Maximum speed		[r/min]	5000								
Permissible instantaneous speed		[r/min]	5750								
Power rate at continuous rated torque	Standard	[kW/s]	22.7	17.2	43.3	50.0	72.7	36.7	82.6	108	
	With electromagnetic brake	[kW/s]	22.0	16.3	42.0	48.2	70.5	31.5	71.0	96.4	
Rated current		[A]	1.0	1.2	2.6	5.6	5.5	4.9	8.3	9.3	
Maximum current		[A]	3.2	3.8	8.3	18	18	16	30	31	
Regenerative braking frequency ^{*2, *3}		[times/min]	(Note 5)	(Note 6)	277	176	143	71	360	263	
Moment of inertia J	Standard	[× 10 ⁻⁴ kg·m ²]	0.0446	0.236	0.374	1.14	1.39	2.76	2.76	3.75	
	With electromagnetic brake	[× 10 ⁻⁴ kg·m ²]	0.0460	0.248	0.386	1.18	1.44	3.21	3.21	4.20	
Recommended load to motor inertia ratio (Note 1)			15 times or less								
Speed/position detector			17-bit incremental encoder (magnetic type) (Note 4) (resolution: 131072 pulses/rev)								
Oil seal			None (Servo motors with oil seal are available. (HJ-KS_J))								
Thermistor			None								
Insulation class			130 (B)								
Structure			Totally enclosed, natural cooling (IP rating: IP65) (Note 2)								
Environment ^{*4}	Ambient temperature		Operation: 0 °C to 40 °C (non-freezing), storage -15 °C to 70 °C (non-freezing)								
	Ambient humidity		Operation: 10 %RH to 80 %RH (non-condensing), storage: 10 %RH to 90 %RH (non-condensing)								
	Ambience		Indoors (no direct sunlight); no corrosive gas, inflammable gas, oil mist or dust								
	Altitude		1000 m or less above sea level								
Vibration resistance ^{*5}			X: 24.5 m/s ² Y: 24.5 m/s ²								
Vibration rank			V10 ^{*7}								
Compliance to global standards			Refer to "Conformity with Global Standards and Regulations" on p. 14 in this catalog.								
Permissible load for the shaft ^{*6}	L	[mm]	25	30	30	40	40	45	45	45	
	Radial	[N]	88	245	245	392	392	686	686	686	
	Thrust	[N]	59	98	98	147	147	196	196	196	
Mass	Standard	[kg]	0.56	1.0	1.4	2.6	3.0	4.3	4.3	5.3	
	With electromagnetic brake	[kg]	0.68	1.3	1.7	3.1	3.5	5.3	5.3	6.3	

- Notes: 1. Contact your local sales office if the load to motor inertia ratio exceeds the value in the table.
 2. The shaft-through portion is excluded. Refer to the asterisk 8 of "Annotations for Servo Motor Specifications" on p. 2-9 in this catalog for the shaft-through portion.
 3. When unbalanced torque is generated, such as in a vertical lift machine, keep the unbalanced torque of the machine under 70% of the servo motor rated torque.
 4. Do not place any object (such as a magnet) which generates a magnetic force near the servo motor. If it is unavoidable, keep the magnetic force received by the servo motor 100 gauss or less by installing a shielding plate, etc.
 5. The regenerative frequency will not be limited if the following requirements are met.
 • When the servo motor decelerates to a stop from the rated speed, the effective torque is within the rated torque.
 • When the servo motor decelerates to a stop from the maximum speed, the load moment of inertia is 15 times or less, and the effective torque is within the rated torque.
 6. The regenerative frequency will not be limited if the following requirements are met.
 • When the servo motor decelerates to a stop from the rated speed, the load moment of inertia is 7 times or less, and the effective torque is within the rated torque.
 • When the servo motor decelerates to a stop from the maximum speed, the load moment of inertia is 2 times or less, and the effective torque is within the rated torque.

Refer to "Annotations for Servo Motor Specifications" on p. 2-9 in this catalog for the asterisks 1 to 7.

Servo Amplifiers

Servo Motors

Options/Peripheral Equipment

LVS/Wires

Product List

Cautions

Servo Motors

HJ-KS 3000 r/min Series Electromagnetic Brake Specifications (Note 1)

Servo motor model	HJ-KS	13B	23B	43B	73B	103AB	103B	153B	203B
Type	Spring actuated type safety brake								
Rated voltage	24 V DC _{-10%}								
Power consumption [W] at 20 °C		6.1	7.2	7.2	9.5	9.5	20.5	20.5	20.5
Electromagnetic brake static friction torque [N·m]		0.33	1.3	1.3	3.3	3.3	10.0	10.0	10.0
Permissible braking work	Per braking [J]	15	87	87	200	200	500	500	500
	Per hour [J]	150	870	870	2000	2000	5000	5000	5000
Electromagnetic brake life (Note 2)	Number of brakings [Times]	200	200	200	200	200	200	200	200
	Work per braking [J]	15	87	87	200	200	500	500	500

Notes: 1. The electromagnetic brake is for holding. It should not be used for deceleration applications.
 2. Brake gap is not adjustable. Electromagnetic brake life is defined as the time period until the readjustment is needed.

HJ-KS 3000 r/min Series Torque Characteristics

HJ-KS13(B) (Note 1, 2, 3)

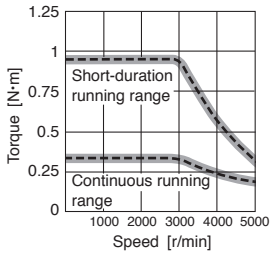

HJ-KS23(B) (Note 1, 2, 3)

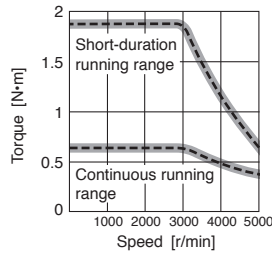

HJ-KS43(B) (Note 1, 2, 3)

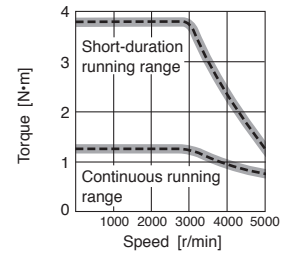

HJ-KS73(B) (Note 1, 2, 3)

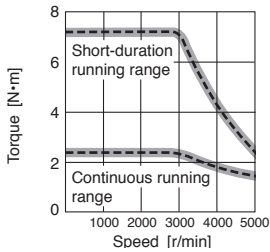

HJ-KS103A(B) (Note 1, 2, 3)

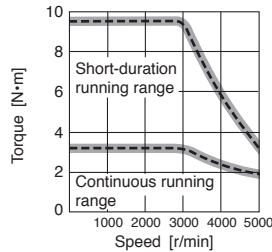

HJ-KS103(B) (Note 1, 2, 3)

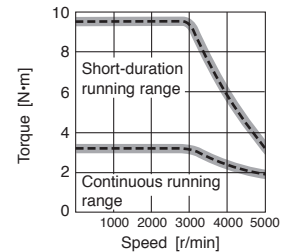

HJ-KS153(B) (Note 1, 2, 3)

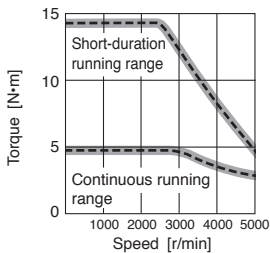

HJ-KS203(B) (Note 1, 2, 3)

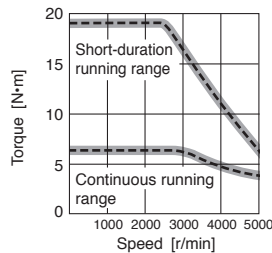

Notes: 1. ——— : For 3-phase 200 V AC.
 2. - - - - : For 1-phase 230 V AC.
 3. Torque drops when the power supply voltage is below the specified value.

HJ-KS 2000 r/min Series (Low Inertia) Specifications

Servo motor model	HJ-KS	102(B)	152(B)	202(B)	
Compatible servo amplifier model		Refer to "Combinations of Servo Motor and Servo Amplifier" on p. 2-2 in this catalog.			
Power supply capacity *1		[kVA]	1.7	2.5	3.5
Continuous running duty	Rated output	[kW]	1.0	1.5	2.0
	Rated torque (Note 3)	[N·m]	4.8	7.2	9.5
Maximum torque		[N·m]	14.3	21.5	28.6
Rated speed		[r/min]	2000		
Maximum speed		[r/min]	3000		
Permissible instantaneous speed		[r/min]	3450		
Power rate at continuous rated torque	Standard	[kW/s]	82.6	137	159
	With electromagnetic brake	[kW/s]	70.9	122	148
Rated current		[A]	4.7	8.2	8.3
Maximum current		[A]	17	29	27
Regenerative braking frequency *2, *3		[times/min]	164	608	393
Moment of inertia J	Standard	[x 10 ⁻⁴ kg·m ²]	2.76	3.75	5.72
	With electromagnetic brake	[x 10 ⁻⁴ kg·m ²]	3.21	4.20	6.17
Recommended load to motor inertia ratio (Note 1)		15 times or less			
Speed/position detector		17-bit incremental encoder (magnetic type) (Note 4) (resolution: 131072 pulses/rev)			
Oil seal		None (Servo motors with oil seal are available. (HJ-KS_J))			
Thermistor		None			
Insulation class		130 (B)			
Structure		Totally enclosed, natural cooling (IP rating: IP65) (Note 2)			
Environment *4	Ambient temperature	Operation: 0 °C to 40 °C (non-freezing), storage: -15 °C to 70 °C (non-freezing)			
	Ambient humidity	Operation: 10 %RH to 80 %RH (non-condensing), storage: 10 %RH to 90 %RH (non-condensing)			
	Ambience	Indoors (no direct sunlight); no corrosive gas, inflammable gas, oil mist or dust			
	Altitude	1000 m or less above sea level			
Vibration resistance *5		X: 24.5 m/s ² Y: 24.5 m/s ²			
Vibration rank		V10 *7			
Compliance to global standards		Refer to "Conformity with Global Standards and Regulations" on p. 14 in this catalog.			
Permissible load for the shaft *6	L	[mm]	45	45	45
	Radial	[N]	686	686	686
	Thrust	[N]	196	196	196
Mass	Standard	[kg]	4.3	5.3	7.2
	With electromagnetic brake	[kg]	5.3	6.3	8.2

- Notes: 1. Contact your local sales office if the load to motor inertia ratio exceeds the value in the table.
 2. The shaft-through portion is excluded. Refer to the asterisk 8 of "Annotations for Servo Motor Specifications" on p. 2-9 in this catalog for the shaft-through portion.
 3. When unbalanced torque is generated, such as in a vertical lift machine, keep the unbalanced torque of the machine under 70% of the servo motor rated torque.
 4. Do not place any object (such as a magnet) which generates a magnetic force near the servo motor. If it is unavoidable, keep the magnetic force received by the servo motor 100 gauss or less by installing a shielding plate, etc.

Refer to "Annotations for Servo Motor Specifications" on p. 2-9 in this catalog for the asterisks 1 to 7.

Servo Amplifiers

Servo Motors

Options/Peripheral Equipment

LVS/Wires

Product List

Cautions

Servo Motors

HJ-KS 2000 r/min Series Electromagnetic Brake Specifications (Note 1)

Servo motor model	HJ-KS	102B	152B	202B
Type	Spring actuated type safety brake			
Rated voltage	24 V DC ^{-10%}			
Power consumption [W] at 20 °C		20.5	20.5	20.5
Electromagnetic brake static friction torque [N·m]		10.0	10.0	10.0
Permissible braking work	Per braking [J]	500	500	500
	Per hour [J]	5000	5000	5000
Electromagnetic brake life (Note 2)	Number of brakings [Times]	200	200	200
	Work per braking [J]	500	500	500

Notes: 1. The electromagnetic brake is for holding. It should not be used for deceleration applications.
 2. Brake gap is not adjustable. Electromagnetic brake life is defined as the time period until the readjustment is needed.

HJ-KS 2000 r/min Series Torque Characteristics

HJ-KS102(B) (Note 1, 2, 3)

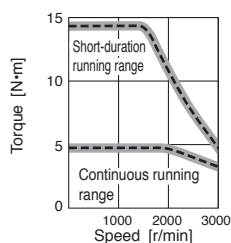

HJ-KS152(B) (Note 1, 2, 3)

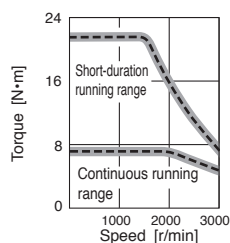

HJ-KS202(B) (Note 1, 2, 3)

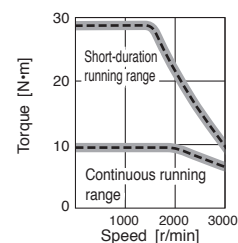

Notes: 1. ——— : For 3-phase 200 V AC.
 2. - - - - : For 1-phase 230 V AC.
 3. Torque drops when the power supply voltage is below the specified value.

HJ-FS Series (High Inertia) Specifications

Servo motor model		HJ-FS	23(B)	43(B)	73(B)	103A(B)
Compatible servo amplifier model		Refer to "Combinations of Servo Motor and Servo Amplifier" on p. 2-2 in this catalog.				
Power supply capacity ^{*1}		[kVA]	0.5	0.9	1.3	1.7
Continuous running duty	Rated output	[kW]	0.2	0.4	0.75	1.0
	Rated torque (Note 3)	[N·m]	0.64	1.3	2.4	3.2
Maximum torque		[N·m]	1.9	3.8	7.2	9.5
Rated speed		[r/min]	3000			
Maximum speed		[r/min]	5000			
Permissible instantaneous speed		[r/min]	5750			
Power rate at continuous rated torque	Standard	[kW/s]	9.5	28.7	38.0	57.8
	With electromagnetic brake	[kW/s]	9.2	28.1	36.9	56.4
Rated current		[A]	1.2	2.6	5.6	5.5
Maximum current		[A]	3.8	8.3	18	18
Regenerative braking frequency ^{*2, *3}		[times/min]	(Note 5)	180	133	113
Moment of inertia J	Standard	[× 10 ⁻⁴ kg·m ²]	0.426	0.564	1.50	1.75
	With electromagnetic brake	[× 10 ⁻⁴ kg·m ²]	0.438	0.576	1.54	1.80
Recommended load to motor inertia ratio (Note 1)		15 times or less				
Speed/position detector		17-bit incremental encoder (magnetic type) (Note 4) (resolution: 131072 pulses/rev)				
Oil seal		None (Servo motors with oil seal are available. (HJ-FS_J))				
Thermistor		None				
Insulation class		130 (B)				
Structure		Totally enclosed, natural cooling (IP rating: IP65) (Note 2)				
Environment ^{*4}	Ambient temperature	Operation: 0 °C to 40 °C (non-freezing), storage: -15 °C to 70 °C (non-freezing)				
	Ambient humidity	Operation: 10 %RH to 80 %RH (non-condensing), storage: 10 %RH to 90 %RH (non-condensing)				
	Ambience	Indoors (no direct sunlight); no corrosive gas, inflammable gas, oil mist or dust				
	Altitude	1000 m or less above sea level				
Vibration resistance ^{*5}		X: 24.5 m/s ² Y: 24.5 m/s ²				
Vibration rank		V10 ⁻⁷				
Compliance to global standards		Refer to "Conformity with Global Standards and Regulations" on p. 14 in this catalog.				
Permissible load for the shaft ^{*6}	L	[mm]	30	30	40	40
	Radial	[N]	245	245	392	392
	Thrust	[N]	98	98	147	147
Mass	Standard	[kg]	1.1	1.5	2.7	3.1
	With electromagnetic brake	[kg]	1.4	1.8	3.2	3.6

- Notes: 1. Contact your local sales office if the load to motor inertia ratio exceeds the value in the table.
 2. The shaft-through portion is excluded. Refer to the asterisk 8 of "Annotations for Servo Motor Specifications" on p. 2-9 in this catalog for the shaft-through portion.
 3. When unbalanced torque is generated, such as in a vertical lift machine, keep the unbalanced torque of the machine under 70% of the servo motor rated torque.
 4. Do not place any object (such as a magnet) which generates a magnetic force near the servo motor. If it is unavoidable, keep the magnetic force received by the servo motor 100 gauss or less by installing a shielding plate, etc.
 5. The regenerative frequency will not be limited if the following requirements are met.
 • When the servo motor decelerates to a stop from the rated speed, the load moment of inertia is 3 times or less, and the effective torque is within the rated torque.
 • When the servo motor decelerates to a stop from the maximum speed, the load moment of inertia is 0.5 times or less, and the effective torque is within the rated torque.

Refer to "Annotations for Servo Motor Specifications" on p. 2-9 in this catalog for the asterisks 1 to 7.

Servo Amplifiers

Servo Motors

Options/Peripheral Equipment

LVS/Wires

Product List

Cautions

Servo Motors

HJ-FS Series Electromagnetic Brake Specifications (Note 1)

Servo motor model	HJ-FS	23B	43B	73B	103AB
Type	Spring actuated type safety brake				
Rated voltage	24 V DC _{-10%}				
Power consumption [W] at 20 °C		7.2	7.2	9.5	9.5
Electromagnetic brake static friction torque [N·m]		1.3	1.3	3.3	3.3
Permissible braking work	Per braking [J]	87	87	200	200
	Per hour [J]	870	870	2000	2000
Electromagnetic brake life (Note 2)	Number of brakings [Times]	200	200	200	200
	Work per braking [J]	87	87	200	200

Notes: 1. The electromagnetic brake is for holding. It should not be used for deceleration applications.

2. Brake gap is not adjustable. Electromagnetic brake life is defined as the time period until the readjustment is needed.

HJ-FS Series Torque Characteristics

HJ-FS23(B) (Note 1, 2, 3)

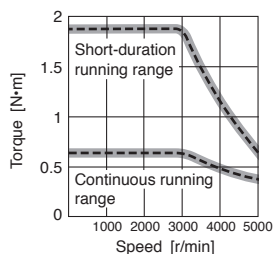

HJ-FS43(B) (Note 1, 2, 3)

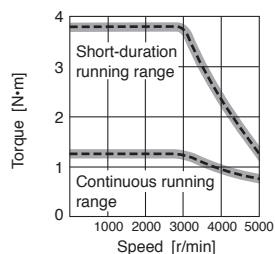

HJ-FS73(B) (Note 1, 2, 3)

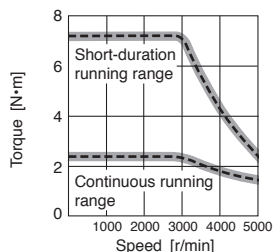

HJ-FS103A(B) (Note 1, 2, 3)

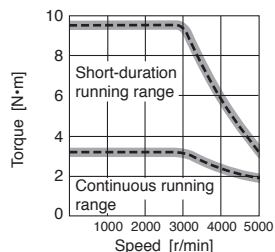

Notes: 1. — : For 3-phase 200 V AC.

2. - - - : For 1-phase 230 V AC.

3. Torque drops when the power supply voltage is below the specified value.

Annotations for Servo Motor Specifications

- *1. The power supply capacity varies depending on the power supply impedance.
- *2. The regenerative braking frequency shows the permissible frequency when the servo motor, without a load and a regenerative option, decelerates from the rated speed to a stop. When a load is connected; however, the value will be the table value/(m+1), where m = Moment of inertia of load/Moment of inertia of servo motor. When the operating speed exceeds the rated speed, the regenerative braking frequency is inversely proportional to the square of (operating speed/rated speed). Take measures to keep the regenerative power [W] during operation below the permissible regenerative power [W]. Use caution, especially when the operating speed changes frequently or when the regeneration is constant (as with vertical feeds). Select the most suitable regenerative option for your system with our capacity selection software. Refer to "Regenerative Option" in this catalog for the permissible regenerative power [W] when regenerative option is used.
- *3. For 400 W or smaller servo amplifiers, the regenerative braking frequency may change affected by the power supply voltage due to the large ratio of the energy charged into the electrolytic capacitor in the servo amplifier.
- *4. In the environment where the servo motor is exposed to oil mist, oil and/or water, a standard specification servo motor may not be usable. Contact your local sales office for more details.
- *5. The vibration direction is shown in the diagram below. The numerical value indicates the maximum value of the component (commonly the bracket in the opposite direction of the servo motor shaft). Fretting tends to occur on the bearing when the servo motor stops. Thus, maintain vibration level at approximately one-half of the allowable value.

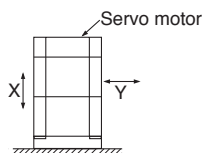

- *6. Refer to the diagram below for the permissible load for the shaft. Do not apply a load exceeding the value specified in the table on the shaft. The values in the table are applicable when each load is applied singly.

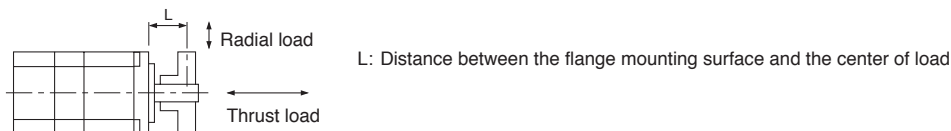

- *7. V10 indicates that the amplitude of the servo motor itself is 10 μm or less. The following shows mounting posture and measuring position of the servo motor during the measurement:

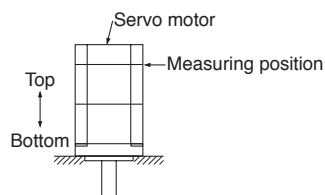

- *8. Refer to the diagram below for shaft-through portion.

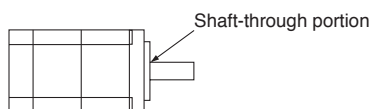

Servo Motors

HJ-KS/HJ-FS Series Dimensions (Note 1, 5)

●HJ-KS13(B)(J)

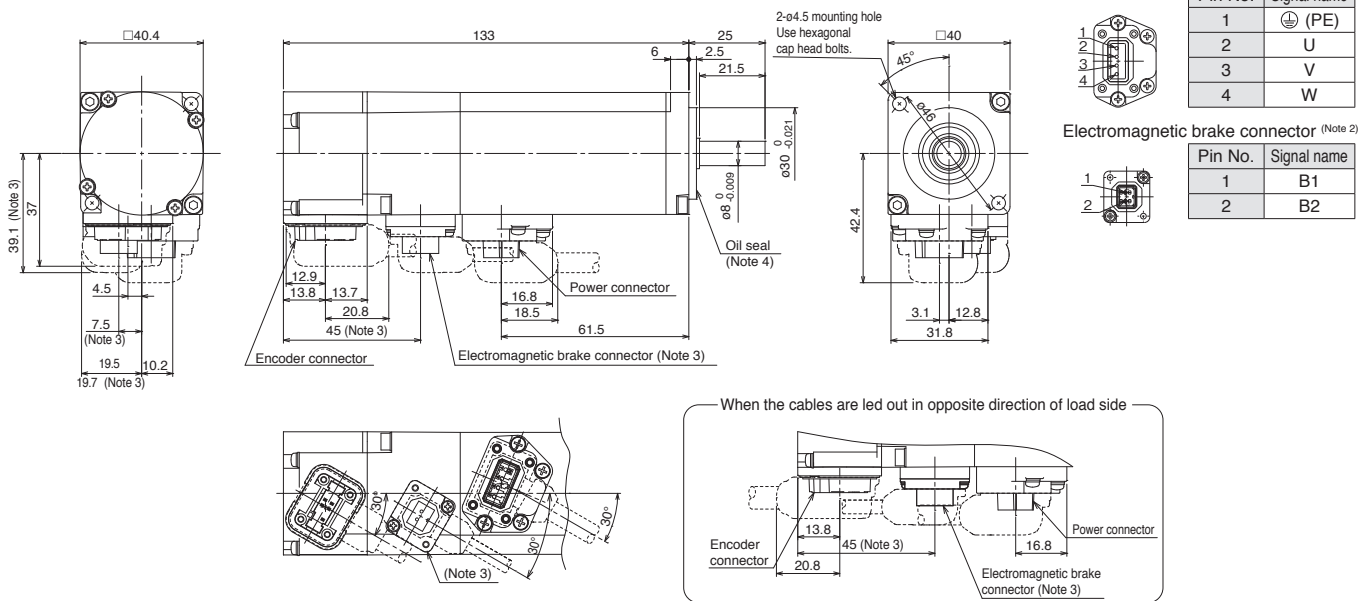

[Unit: mm]

●HJ-KS23(B)(J), HJ-KS43(B)(J)

●HJ-FS23(B)(J), HJ-FS43(B)(J)

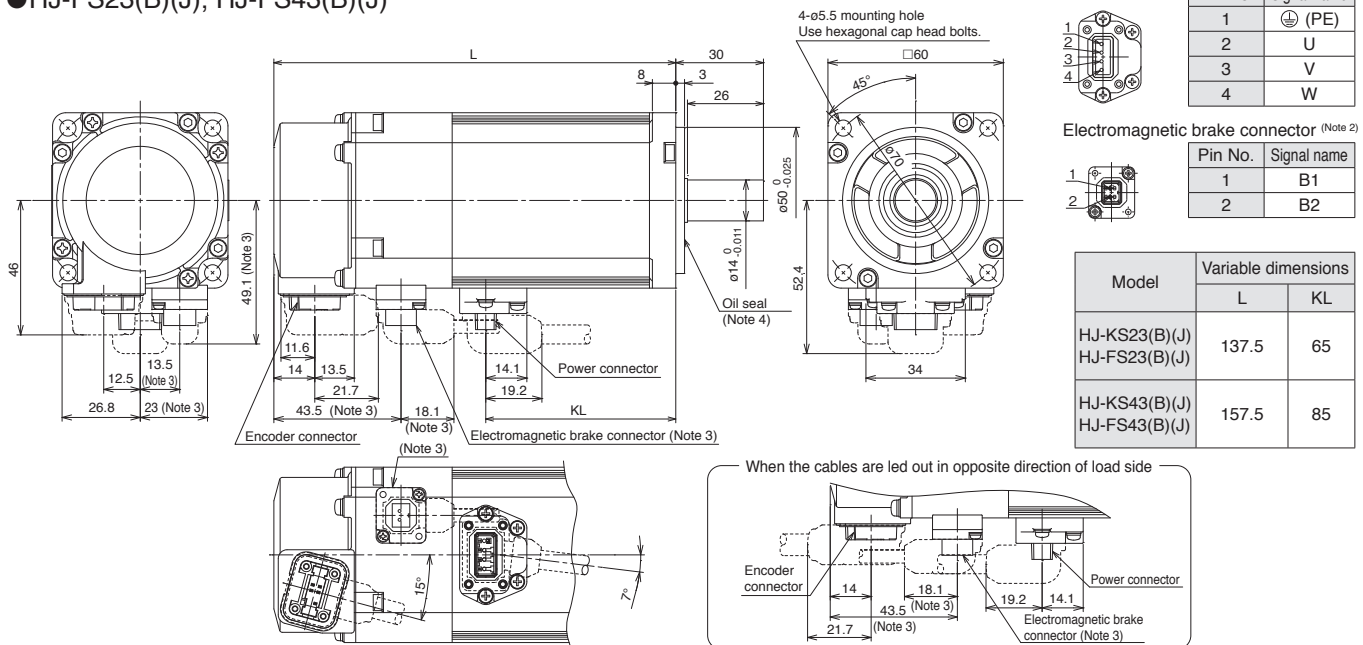

[Unit: mm]

- Notes: 1. For dimensions without tolerance, general tolerance applies.
 2. The electromagnetic brake terminals (B1, B2) do not have polarity.
 3. Only for the models with electromagnetic brake.
 4. Only for the models with oil seal.
 5. Use a friction coupling to fasten a load.

HJ-KS/HJ-FS Series Dimensions (Note 1, 5)

- HJ-KS73(B)(J), HJ-KS103A(B)(J)
- HJ-FS73(B)(J), HJ-FS103A(B)(J)

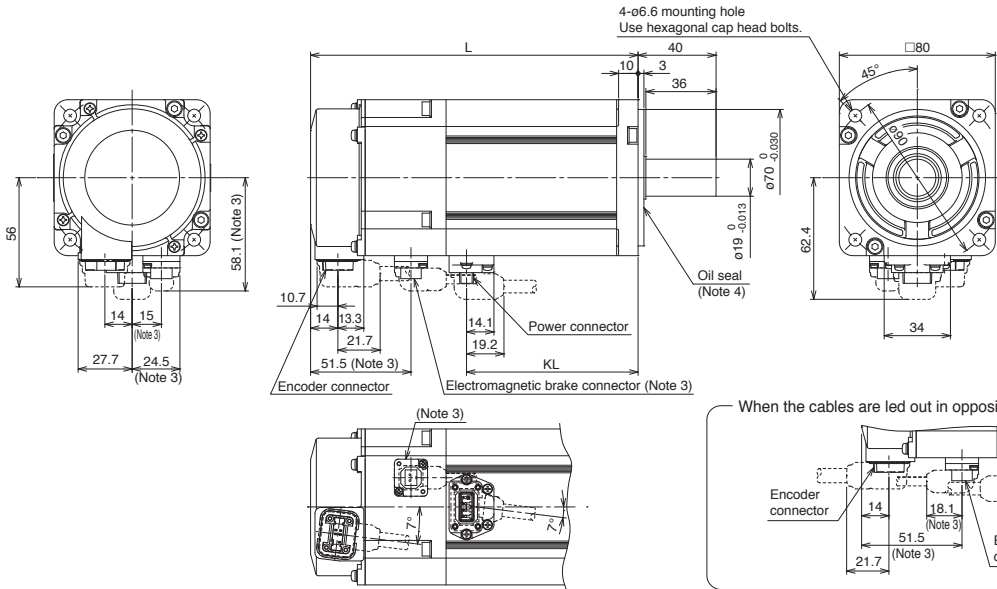

Power connector

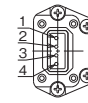

Pin No.	Signal name
1	⊕ (PE)
2	U
3	V
4	W

Electromagnetic brake connector (Note 2)



Pin No.	Signal name
1	B1
2	B2

Model	Variable dimensions	
	L	KL
HJ-KS73(B)(J) HJ-FS73(B)(J)	168	88
HJ-KS103A(B)(J) HJ-FS103A(B)(J)	180	100

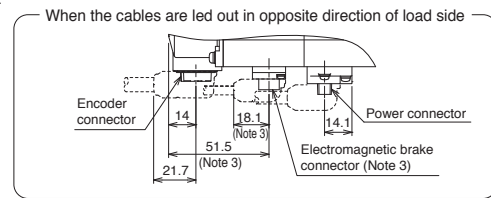

[Unit: mm]

- HJ-KS103(B)(J), HJ-KS153(B)(J), HJ-KS203(B)(J)
- HJ-KS102(B)(J), HJ-KS152(B)(J), HJ-KS202(B)(J)

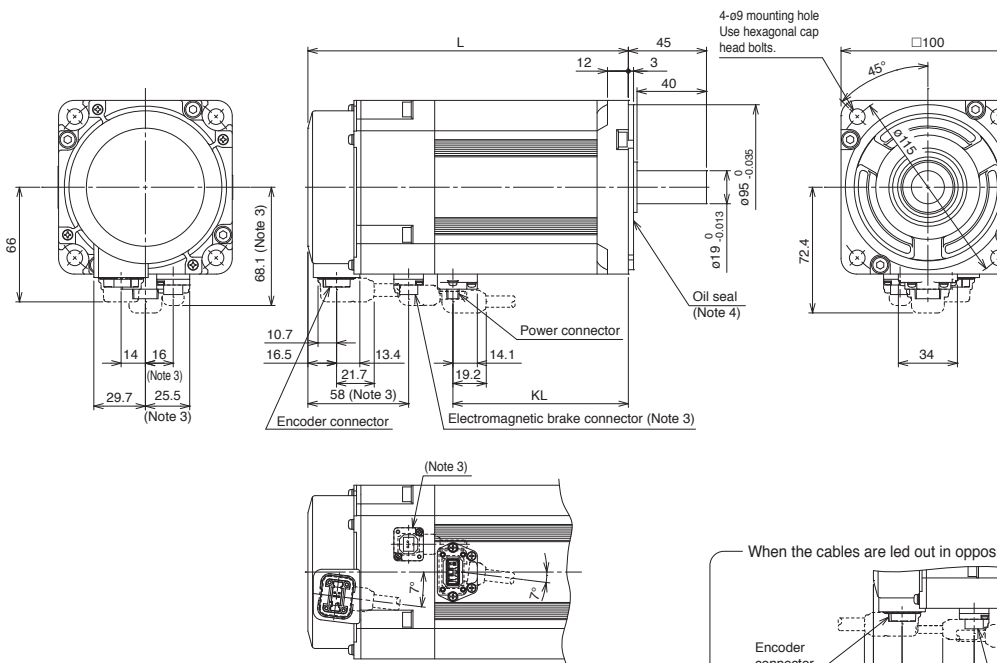

Power connector

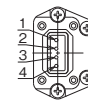

Pin No.	Signal name
1	⊕ (PE)
2	U
3	V
4	W

Electromagnetic brake connector (Note 2)



Pin No.	Signal name
1	B1
2	B2

Model	Variable dimensions	
	L	KL
HJ-KS103(B)(J) HJ-KS153(B)(J) HJ-KS102(B)(J)	184.5	101
HJ-KS203(B)(J) HJ-KS152(B)(J)	206.5	123
HJ-KS202(B)(J)	250.5	167

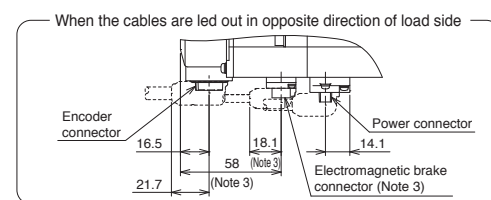

[Unit: mm]

- Notes:
1. For dimensions without tolerance, general tolerance applies.
 2. The electromagnetic brake terminals (B1, B2) do not have polarity.
 3. Only for the models with electromagnetic brake.
 4. Only for the models with oil seal.
 5. Use a friction coupling to fasten a load.

Servo Motors

Servo Motor Sizing Example

1. Selection criteria

(1) Configurations

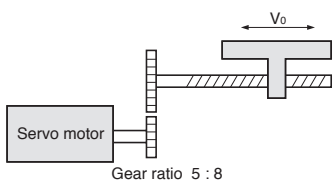

Feed speed of moving part
 Feed length per cycle
 Positioning time
 Number of feed times
 (Operating cycle)
 Reduction ratio
 Moving part mass
 Drive system efficiency
 Friction coefficient
 Ball screw lead

$V_0 = 30000$ mm/min
 $\ell = 400$ mm
 $t_0 =$ within 1 s
 40 times/min
 $t_r = 1.5$ s
 $1/n = 5/8$
 $W = 60$ kg
 $\eta = 0.8$
 $\mu = 0.2$
 $P_B = 16$ mm

$D_B =$ ball screw diameter 20 mm
 $L_B =$ ball screw length 500 mm
 $D_{G1} =$ gear diameter (servo motor shaft) 25 mm
 $D_{G2} =$ gear diameter (load shaft) 40 mm
 $L_G =$ gear tooth thickness 10 mm

(2) Servo motor speed

$$N_0 = \frac{V_0}{P_B} \times \frac{1}{1/n} = \frac{30000}{16} \times \frac{8}{5} = 3000 \text{ r/min}$$

(3) Acceleration/deceleration time constant

$$t_{psa} = t_{psd} = t_0 - \frac{\ell}{V_0/60} - t_s = 0.05 \text{ s}$$

t_s : settling time. Here assumed 0.15 s.

(4) Operating pattern

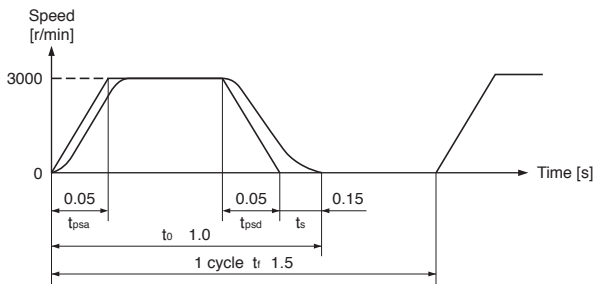

(3) Select a servo motor

Selection criteria

Load torque < Rated torque of servo motor
 Moment of inertia of all loads < J_R × Moment of inertia of servo motor

J_R : Recommended load to motor inertia ratio

Select the following servo motor to meet the criteria above.

HJ-KS23 (rated torque: 0.64 N·m, max. torque: 1.9 N·m, moment of inertia: 0.236×10^{-4} kg·m²)

(4) Acceleration/deceleration torque

Torque required during acceleration

$$T_{Ma} = \frac{(J_L / \eta + J_M) \times N_0}{9.55 \times 10^4 \times t_{psa}} + T_L = 1.85 \text{ N}\cdot\text{m}$$

J_M : moment of inertia of servo motor

Torque required during deceleration

$$T_{Md} = -\frac{(J_L \times \eta + J_M) \times N_0}{9.55 \times 10^4 \times t_{psd}} + T_L = -0.86 \text{ N}\cdot\text{m}$$

Torque required during acceleration/deceleration must be equal to or lower than the max. torque of the servo motor.

2. Selecting servo motor

(1) Load torque (converted into the servo motor shaft)

Travel distance per servo motor revolution

$$\Delta S = P_B \times \frac{1}{n} = 10 \text{ mm}$$

$$T_L = \frac{\mu \times W \times g \times \Delta S}{2 \times 10^3 \pi \eta} = 0.23 \text{ N}\cdot\text{m}$$

(2) Moment of inertia of load (converted into the servo motor shaft)

Moving part

$$J_{L1} = W \times \left(\frac{\Delta S \times 10^{-3}}{2\pi} \right)^2 = 1.52 \times 10^{-4} \text{ kg}\cdot\text{m}^2$$

Ball screw

$$J_{L2} = \frac{\pi \times \rho \times L_B}{32} \times D_B^4 \times \left(\frac{1}{n} \right)^2 = 0.24 \times 10^{-4} \text{ kg}\cdot\text{m}^2$$

$\rho = 7.8 \times 10^3$ kg/m³ (iron)

Gear (servo motor shaft)

$$J_{L3} = \frac{\pi \times \rho \times L_G}{32} \times D_{G1}^4 = 0.03 \times 10^{-4} \text{ kg}\cdot\text{m}^2$$

Gear (load shaft)

$$J_{L4} = \frac{\pi \times \rho \times L_G}{32} \times D_{G2}^4 \times \left(\frac{1}{n} \right)^2 = 0.08 \times 10^{-4} \text{ kg}\cdot\text{m}^2$$

Moment of inertia of all loads (converted into the servo motor shaft)

$$J_L = J_{L1} + J_{L2} + J_{L3} + J_{L4} = 1.87 \times 10^{-4} \text{ kg}\cdot\text{m}^2$$

(5) Continuous effective load torque

$$T_{rms} = \sqrt{\frac{T_{Ma}^2 \times t_{psa} + T_L^2 \times t_c + T_{Md}^2 \times t_{psd}}{t_r}} = 0.41 \text{ N}\cdot\text{m}$$

$t_c = t_0 - t_s - t_{psa} - t_{psd}$

Continuous effective load torque must be equal to or lower than the rated torque of the servo motor.

(6) Torque pattern

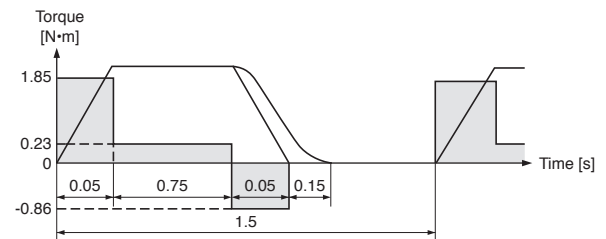

(7) Result

Select the following:

Servo motor: HJ-KS23

Servo amplifier: MR-JE-20AS

[Free capacity selection software]

Capacity selection software (MRZJW3-MOTSZ111E) does all the calculations for you. The capacity selection software is available for free download. Contact your local sales office for more details.

* Be sure to update your MRZJW3-MOTSZ111E to the latest version.

3

Options/Peripheral Equipment

Basic Cable Configurations for Servo Motors.....	3-2
Configuration Example for Servo Motors.....	3-3
Details of Optional Cables and Connectors for Servo Motors.....	3-8
Products on the Market for Servo Motors.....	3-10
Configuration Example for MR-JE-AS.....	3-11
Details of Optional Cables and Connectors for Servo Amplifiers ..	3-13
Products on the Market for Servo Amplifiers	3-14
Regenerative Option.....	3-15
Junction Terminal Block.....	3-17
Radio Noise Filter	3-17
Line Noise Filter.....	3-17
Data Line Filter	3-17
Surge Killer	3-17
EMC Filter.....	3-18
Power Factor Improving AC Reactor	3-19
Servo Support Software	3-20

Options/Peripheral Equipment

Basic Cable Configurations for Servo Motors

Necessary optional cables and connectors vary depending on the servo motor series.
Refer to the following tables for necessary options.

Encoder cable list

Cable length	IP rating ^(Note 1)	Cable lead out direction	Bending life	Model	Reference	Note
10 m or shorter (direct connection type)	IP65	In direction of load side	Long bending life	MR-J3ENCBL_M-A1-H	p. 3-5	
			Standard	MR-J3ENCBL_M-A1-L		
		In opposite direction of load side	Long bending life	MR-J3ENCBL_M-A2-H	p. 3-5	
			Standard	MR-J3ENCBL_M-A2-L		
Exceeding 10 m (junction type)	IP20	In direction of load side	Long bending life	Two types of cables are required: MR-J3JCBL03M-A1-L, MR-EKCBL_M-H	p. 3-5	
			Standard	Two types of cables are required: MR-J3JCBL03M-A1-L, MR-EKCBL_M-L		
		In opposite direction of load side	Long bending life	Two types of cables are required: MR-J3JCBL03M-A2-L, MR-EKCBL_M-H	p. 3-5	
			Standard	Two types of cables are required: MR-J3JCBL03M-A2-L, MR-EKCBL_M-L		
	IP65	In direction of load side	Long bending life	Two types of cables are required: MR-J3JSCBL03M-A1-L, MR-J3ENSCBL_M-H	pp. 3-5 and 3-6	
			Standard	Two types of cables are required: MR-J3JSCBL03M-A1-L, MR-J3ENSCBL_M-L		
		In opposite direction of load side	Long bending life	Two types of cables are required: MR-J3JSCBL03M-A2-L, MR-J3ENSCBL_M-H	pp. 3-5 and 3-6	
			Standard	Two types of cables are required: MR-J3JSCBL03M-A2-L, MR-J3ENSCBL_M-L		

Servo motor power cable list

Cable length	IP rating ^(Note 1)	Cable lead out direction	Bending life	Model	Reference	Note
10 m or shorter (direct connection type)	IP65	In direction of load side	Long bending life	MR-PWS1CBL_M-A1-H	p. 3-7	Select one from this list.
			Standard	MR-PWS1CBL_M-A1-L		
		In opposite direction of load side	Long bending life	MR-PWS1CBL_M-A2-H	p. 3-7	
			Standard	MR-PWS1CBL_M-A2-L		
Exceeding 10 m (junction type)	IP55	In direction of load side	Standard	Connect a user-fabricated cable to MR-PWS2CBL03M-A1-L (optional cable).	p. 3-7	
		In opposite direction of load side		Connect a user-fabricated cable to MR-PWS2CBL03M-A2-L (optional cable).	p. 3-7	

Electromagnetic brake cable list

Cable length	IP rating ^(Note 1)	Cable lead out direction	Bending life	Model	Reference	Note
10 m or shorter (direct connection type)	IP65	In direction of load side	Long bending life	MR-BKS1CBL_M-A1-H	p. 3-7	Select one from this list.
			Standard	MR-BKS1CBL_M-A1-L		
		In opposite direction of load side	Long bending life	MR-BKS1CBL_M-A2-H	p. 3-7	
			Standard	MR-BKS1CBL_M-A2-L		
Exceeding 10 m (junction type)	IP55	In direction of load side	Standard	Connect a user-fabricated cable to MR-BKS2CBL03M-A1-L (optional cable).	p. 3-7	
		In opposite direction of load side		Connect a user-fabricated cable to MR-BKS2CBL03M-A2-L (optional cable).	p. 3-7	

Notes: 1. The IP rating indicated is for the connector's protection against ingress of dust and water when coupled to a servo amplifier/servo motor. If the IP rating of the servo amplifier/servo motor differs from that of these connectors, overall IP rating depends on the lowest of all.

Configuration Example for Servo Motors

For HJ-KS/HJ-FS servo motor series: encoder cable length 10 m or shorter

- For leading the cables out in direction of load side (Note 1)

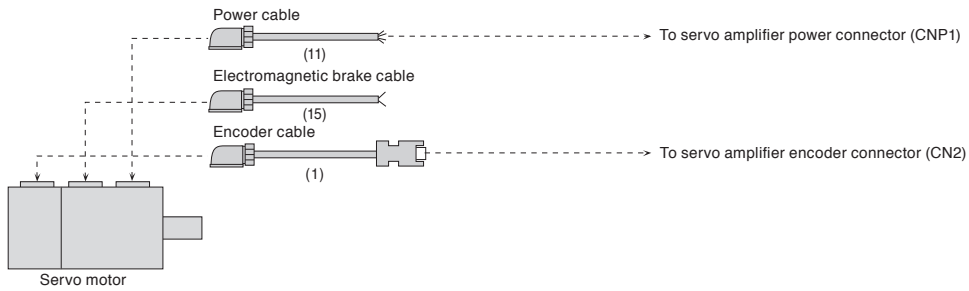

- For leading the cables out in opposite direction of load side (Note 1)

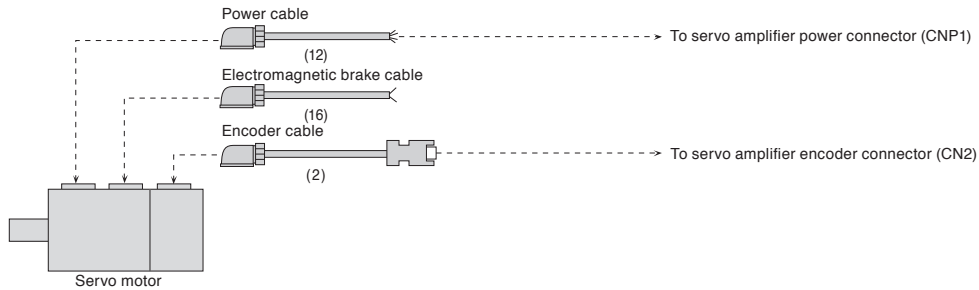

Notes: 1. Cables for leading two different directions may be used for one servo motor.

Options/Peripheral Equipment

Configuration Example for Servo Motors ^(Note 5)

For HJ-KS/HJ-FS servo motor series: encoder cable length over 10 m

- For leading the cables out in direction of load side ^(Note 4)

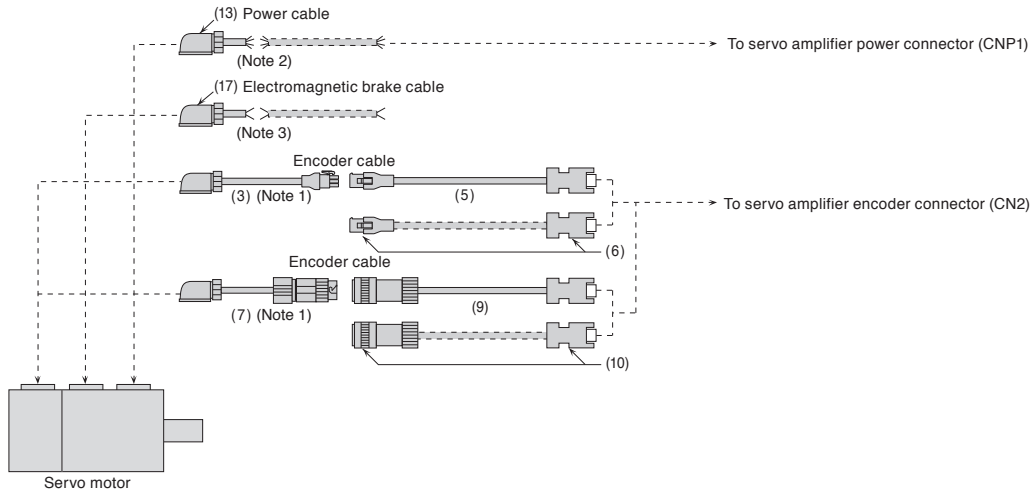

- For leading the cables out in opposite direction of load side ^(Note 4)

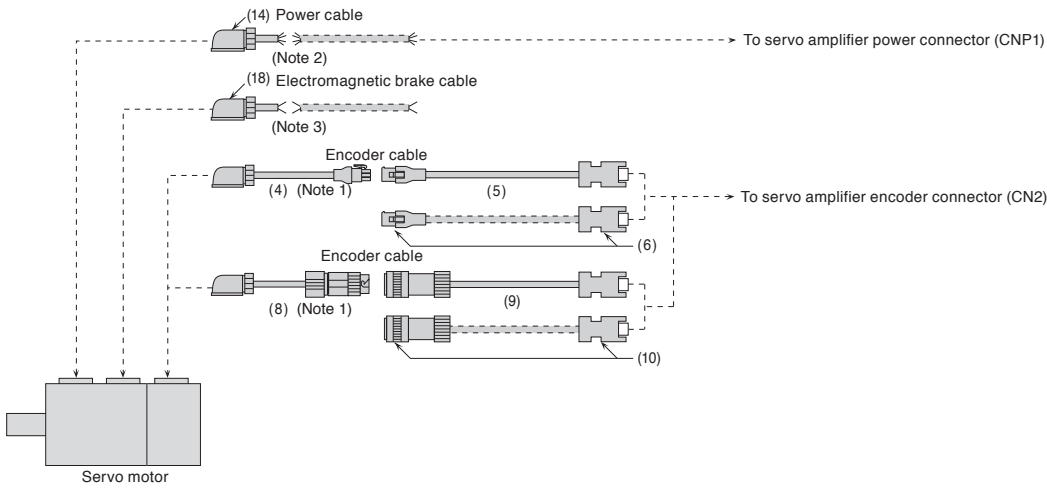



- Notes:
1. This cable does not have a long bending life. Thus, be sure to fix the cable before using.
 2. Relay a cable using MR-PWS2CBL03M-A1-L or MR-PWS2CBL03M-A2-L. This cable does not have a long bending life. Thus, be sure to fix the cable before using.
 3. Relay a cable using MR-BKS2CBL03M-A1-L or MR-BKS2CBL03M-A2-L. This cable does not have a long bending life. Thus, be sure to fix the cable before using.
 4. Cables for leading two different directions may be used for one servo motor.
 5. Cables drawn with dashed lines need to be fabricated by user. Refer to "MR-JE-_AS HJ-KS_ HJ-FS_ Instruction Manual" for fabricating the cables.

Cables and Connectors for Servo Motor Encoder

Refer to "Details of Optional Cables and Connectors for Servo Motors" in this catalog for the detailed models.

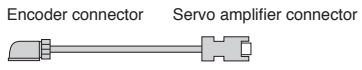
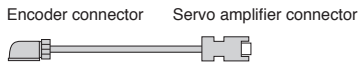
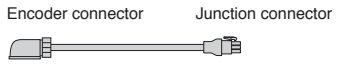
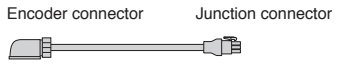
Encoder cables are not subject to European Low Voltage Directive (50 V AC to 1000 V AC and 75 V DC to 1500 V DC).

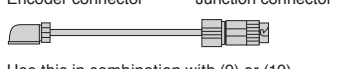
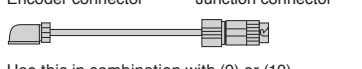
	Item	Model	Cable length	IP rating (Note 1)	Application	Description
(1)	Encoder cable (Note 2) (load-side lead)	MR-J3ENCBL2M-A1-H ^{*1}	2 m	IP65	For HJ-KS/HJ-FS (direct connection type)	
		MR-J3ENCBL5M-A1-H ^{*1}	5 m			
		MR-J3ENCBL10M-A1-H ^{*1}	10 m			
		MR-J3ENCBL2M-A1-L ^{*1}	2 m			
		MR-J3ENCBL5M-A1-L ^{*1}	5 m			
		MR-J3ENCBL10M-A1-L ^{*1}	10 m			
(2)	Encoder cable (Note 2) (opposite to load-side lead)	MR-J3ENCBL2M-A2-H ^{*1}	2 m	IP65	For HJ-KS/HJ-FS (direct connection type)	
		MR-J3ENCBL5M-A2-H ^{*1}	5 m			
		MR-J3ENCBL10M-A2-H ^{*1}	10 m			
		MR-J3ENCBL2M-A2-L ^{*1}	2 m			
		MR-J3ENCBL5M-A2-L ^{*1}	5 m			
		MR-J3ENCBL10M-A2-L ^{*1}	10 m			
(3)	Encoder cable (Note 2) (load-side lead)	MR-J3JCB03M-A1-L ^{*1}	0.3 m	IP20	For HJ-KS/HJ-FS (junction type)	
(4)	Encoder cable (Note 2) (opposite to load-side lead)	MR-J3JCB03M-A2-L ^{*1}	0.3 m	IP20	For HJ-KS/HJ-FS (junction type)	 Use this in combination with (5) or (6).
(5)	Encoder cable (Note 2)	MR-EKCBL20M-H ^{*1}	20 m	IP20	For HJ-KS/HJ-FS (junction type)	
		MR-EKCBL30M-H ^{*1}	30 m			
		MR-EKCBL40M-H ^{*1}	40 m			
		MR-EKCBL50M-H ^{*1}	50 m			
		MR-EKCBL20M-L ^{*1}	20 m			
		MR-EKCBL30M-L ^{*1}	30 m			
(6)	Encoder connector set	MR-ECNM	-	IP20	For HJ-KS/HJ-FS (junction type)	 Use this in combination with (3) or (4). Applicable cable Wire size: 0.3 mm ² (AWG 22) Cable OD: 8.2 mm Crimping tool (91529-1) is required.
(7)	Encoder cable (Note 2) (load-side lead)	MR-J3JSCBL03M-A1-L ^{*1}	0.3 m	IP65 (Note 3)	For HJ-KS/HJ-FS (junction type)	
(8)	Encoder cable (Note 2) (opposite to load-side lead)	MR-J3JSCBL03M-A2-L ^{*1}	0.3 m	IP65 (Note 3)	For HJ-KS/HJ-FS (junction type)	 Use this in combination with (9) or (10).

Notes: 1. The IP rating indicated is for the connector's protection against ingress of dust and water when coupled to a servo amplifier/servo motor. If the IP rating of the servo amplifier/servo motor differs from that of these connectors, overall IP rating depends on the lowest of all.

2. -H and -L indicate a bending life. -H indicates a long bending life, and -L indicates a standard bending life.

3. The encoder cable is rated IP65 while the junction connector itself is rated IP67.

For unlisted lengths



*1. For unlisted lengths of the cables, please contact Mitsubishi Electric System & Service Co., Ltd. OVERSEAS BUSINESS PROMOTION DIVISION (Email: osb.webmaster@melsc.jp)

Options/Peripheral Equipment

Cables and Connectors for Servo Motor Encoder

Refer to "Details of Optional Cables and Connectors for Servo Motors" in this catalog for the detailed models.

Encoder cables are not subject to European Low Voltage Directive (50 V AC to 1000 V AC and 75 V DC to 1500 V DC).

Item	Model	Cable length	IP rating (Note 1)	Application	Description
(9) Encoder cable (Note 2)	MR-J3ENSCBL2M-H ^{*1}	2 m	IP67	For HJ-KS/HJ-FS (junction type)	Junction connector or encoder connector Servo amplifier connector  Use this in combination with (7) or (8) for HJ-KS/HJ-FS series.
	MR-J3ENSCBL5M-H ^{*1}	5 m			
	MR-J3ENSCBL10M-H ^{*1}	10 m			
	MR-J3ENSCBL20M-H ^{*1}	20 m			
	MR-J3ENSCBL30M-H ^{*1}	30 m			
	MR-J3ENSCBL40M-H ^{*1}	40 m			
	MR-J3ENSCBL50M-H ^{*1}	50 m			
	MR-J3ENSCBL2M-L ^{*1}	2 m			
	MR-J3ENSCBL5M-L ^{*1}	5 m			
	MR-J3ENSCBL10M-L ^{*1}	10 m			
	MR-J3ENSCBL20M-L ^{*1}	20 m			
	MR-J3ENSCBL30M-L ^{*1}	30 m			
(10) Encoder connector set (Note 4) (one-touch connection type)	MR-J3SCNS	-	IP67	For HJ-KS/HJ-FS (junction type)	Junction connector or encoder connector Servo amplifier connector  Use this in combination with (7) or (8) for HJ-KS/HJ-FS series. Applicable cable Wire size: 0.5 mm ² (AWG 20) or smaller Cable OD: 5.5 mm to 9.0 mm (Note 3)

Notes: 1. The IP rating indicated is for the connector's protection against ingress of dust and water when coupled to a servo amplifier/servo motor. If the IP rating of the servo amplifier/servo motor differs from that of these connectors, overall IP rating depends on the lowest of all.

2. -H and -L indicate a bending life. -H indicates a long bending life, and -L indicates a standard bending life.

3. Cable clamps and bushings for cable OD of 5.5 mm to 7.5 mm and of 7.0 mm to 9.0 mm are included in the set.





4. The connector contains a plug and contacts. Using contacts for other plugs may damage the connector. Be sure to use the enclosed contacts.

For unlisted lengths

*1. For unlisted lengths of the cables, please contact Mitsubishi Electric System & Service Co., Ltd. OVERSEAS BUSINESS PROMOTION DIVISION (Email: osb.webmaster@melsc.jp)

Cables and Connectors for Servo Motor Power/Electromagnetic Brake

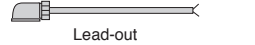
Refer to "Details of Optional Cables and Connectors for Servo Motors" in this catalog for the detailed models.

	Item	Model	Cable length	IP rating (Note 1)	Application	Description
(11)	Power cable (Note 2) (load-side lead)	MR-PWS1CBL2M-A1-H ^{*1}	2 m	IP65	For HJ-KS/HJ-FS (direct connection type)	 Power connector Lead-out
		MR-PWS1CBL5M-A1-H ^{*1}	5 m			
		MR-PWS1CBL10M-A1-H ^{*1}	10 m			
		MR-PWS1CBL2M-A1-L ^{*1 (Note 3)}	2 m			
		MR-PWS1CBL5M-A1-L ^{*1 (Note 3)}	5 m			
		MR-PWS1CBL10M-A1-L ^{*1 (Note 3)}	10 m			
(12)	Power cable (Note 2) (opposite to load-side lead)	MR-PWS1CBL2M-A2-H ^{*1}	2 m	IP65	For HJ-KS/HJ-FS (direct connection type)	* The cable is not shielded.
		MR-PWS1CBL5M-A2-H ^{*1}	5 m			
		MR-PWS1CBL10M-A2-H ^{*1}	10 m			
		MR-PWS1CBL2M-A2-L ^{*1 (Note 3)}	2 m			
		MR-PWS1CBL5M-A2-L ^{*1 (Note 3)}	5 m			
		MR-PWS1CBL10M-A2-L ^{*1 (Note 3)}	10 m			
(13)	Power cable (Note 2) (load-side lead)	MR-PWS2CBL03M-A1-L	0.3 m	IP55	For HJ-KS/HJ-FS (junction type)	 Power connector Lead-out
(14)	Power cable (Note 2) (opposite to load-side lead)	MR-PWS2CBL03M-A2-L	0.3 m	IP55	For HJ-KS/HJ-FS (junction type)	* The cable is not shielded.
(15)	Electromagnetic brake cable (Note 2) (load-side lead)	MR-BKS1CBL2M-A1-H ^{*1}	2 m	IP65	For HJ-KS/HJ-FS (direct connection type)	 Electromagnetic brake connector Lead-out
		MR-BKS1CBL5M-A1-H ^{*1}	5 m			
		MR-BKS1CBL10M-A1-H ^{*1}	10 m			
		MR-BKS1CBL2M-A1-L ^{*1}	2 m			
		MR-BKS1CBL5M-A1-L ^{*1}	5 m			
		MR-BKS1CBL10M-A1-L ^{*1}	10 m			
(16)	Electromagnetic brake cable (Note 2) (opposite to load-side lead)	MR-BKS1CBL2M-A2-H ^{*1}	2 m	IP65	For HJ-KS/HJ-FS (direct connection type)	* The cable is not shielded.
		MR-BKS1CBL5M-A2-H ^{*1}	5 m			
		MR-BKS1CBL10M-A2-H ^{*1}	10 m			
		MR-BKS1CBL2M-A2-L ^{*1}	2 m			
		MR-BKS1CBL5M-A2-L ^{*1}	5 m			
		MR-BKS1CBL10M-A2-L ^{*1}	10 m			
(17)	Electromagnetic brake cable (Note 2) (load-side lead)	MR-BKS2CBL03M-A1-L	0.3 m	IP55	For HJ-KS/HJ-FS (junction type)	 Electromagnetic brake connector Lead-out
(18)	Electromagnetic brake cable (Note 2) (opposite to load-side lead)	MR-BKS2CBL03M-A2-L	0.3 m	IP55	For HJ-KS/HJ-FS (junction type)	* The cable is not shielded.

Notes: 1. The IP rating indicated is for the connector's protection against ingress of dust and water when coupled to a servo amplifier/servo motor. If the IP rating of the servo amplifier/servo motor differs from that of these connectors, overall IP rating depends on the lowest of all.

2. -H and -L indicate a bending life. -H indicates a long bending life, and -L indicates a standard bending life.



3. Shielded power cable MR-PWS3CBL_M-A_-L is also available. Contact your local sales office.



For unlisted lengths



*1. For unlisted lengths of the cables, please contact Mitsubishi Electric System & Service Co., Ltd. OVERSEAS BUSINESS PROMOTION DIVISION (Email: osb.webmaster@meisc.jp)



Options/Peripheral Equipment



Details of Optional Cables and Connectors for Servo Motors



Model	Encoder connector	Servo amplifier connector
MR-J3ENCBL_M-A1-H (Note 2) MR-J3ENCBL_M-A1-L (Note 2) MR-J3ENCBL_M-A2-H (Note 2) MR-J3ENCBL_M-A2-L (Note 2)	 2174053-1 (TE Connectivity Ltd. Company)	 Receptacle: 36210-0100PL Shell kit: 36310-3200-008 (3M) or Connector set: 54599-1019 (Molex)

Model	Encoder connector	Junction connector
MR-J3JCBLO3M-A1-L (Note 2) MR-J3JCBLO3M-A2-L (Note 2)	 2174053-1 (TE Connectivity Ltd. Company)	 Contact: 1473226-1 (with ring) Housing: 1-172169-9 Cable clamp: 316454-1 (TE Connectivity Ltd. Company)

Model	Junction connector	Servo amplifier connector
MR-EKCBL_M-H MR-EKCBL_M-L MR-ECNM	 Housing: 1-172161-9 Connector pin: 170359-1 (TE Connectivity Ltd. Company) or an equivalent product Cable clamp: MTI-0002 (Toa Electric Industrial Co., Ltd.)	 Receptacle: 36210-0100PL Shell kit: 36310-3200-008 (3M) or Connector set: 54599-1019 (Molex)

Model	Encoder connector	Junction connector
MR-J3JSCBLO3M-A1-L (Note 2) MR-J3JSCBLO3M-A2-L (Note 2)	 2174053-1 (TE Connectivity Ltd. Company)	 Cable receptacle: CM10-CR10P-M (DDK Ltd.)

Model	Encoder connector	Servo amplifier connector
MR-J3ENCSCBL_M-H (Note 2) MR-J3ENCSCBL_M-L (Note 2)	 For 10 m or shorter cable Straight plug: CMV1-SP10S-M1 Socket contact: CMV1-#22ASC-C1-100 For 20 m or longer cable Straight plug: CMV1-SP10S-M1 (long bending life) CMV1-SP10S-M2 (standard) Socket contact: CMV1-#22ASC-C2-100 (DDK Ltd.)	 Receptacle: 36210-0100PL Shell kit: 36310-3200-008 (3M) or Connector set: 54599-1019 (Molex)

Model	Junction connector/encoder connector	Servo amplifier connector
MR-J3SCNS (Note 2, 3)	 Straight plug: CMV1-SP10S-M2 (Note 1) Socket contact: CMV1-#22ASC-S1-100 (DDK Ltd.)	 Receptacle: 36210-0100PL Shell kit: 36310-3200-008 (3M) or Connector set: 54599-1019 (Molex)

Notes: 1. Cable clamps and bushings for cable OD of 5.5 mm to 7.5 mm and of 7.0 mm to 9.0 mm are included in the set.

2. The cable or the connector set may contain different connectors but still usable.

3. The connector contains a plug and contacts. Using contacts for other plugs may damage the connector. Be sure to use the enclosed contacts.

Details of Optional Cables and Connectors for Servo Motors

Model	Power connector
MR-PWS1CBL_M-A1-H (Note 1) MR-PWS1CBL_M-A1-L (Note 1) MR-PWS1CBL_M-A2-H (Note 1) MR-PWS1CBL_M-A2-L (Note 1)	 <p>Plug: KN4FT04SJ1-R Socket contact: ST-TMH-S-C1B-100-(A534G) (Japan Aviation Electronics Industry, Limited)</p>

Model	Power connector
MR-PWS2CBL03M-A1-L (Note 1) MR-PWS2CBL03M-A2-L (Note 1)	 <p>Plug: KN4FT04SJ2-R Socket contact: ST-TMH-S-C1B-100-(A534G) (Japan Aviation Electronics Industry, Limited)</p>

Model	Electromagnetic brake connector
MR-BKS1CBL_M-A1-H MR-BKS1CBL_M-A1-L MR-BKS1CBL_M-A2-H MR-BKS1CBL_M-A2-L	 <p>Plug: JN4FT02SJ1-R Socket contact: ST-TMH-S-C1B-100-(A534G) (Japan Aviation Electronics Industry, Limited)</p>

Model	Electromagnetic brake connector
MR-BKS2CBL03M-A1-L MR-BKS2CBL03M-A2-L	 <p>Plug: JN4FT02SJ2-R Socket contact: ST-TMH-S-C1B-100-(A534G) (Japan Aviation Electronics Industry, Limited)</p>

Notes: 1. The cable or the connector set may contain different connectors but still usable.

Options/Peripheral Equipment

Products on the Market for Servo Motors

Contact the relevant manufacturers directly.

When fabricating a cable with the following connectors, refer to the relevant manufacturers' instruction manuals for wiring and assembling procedures.

Encoder connector (servo amplifier-side)



Application	Connector (3M)
Servo amplifier CN2 connector	Receptacle: 36210-0100PL Shell kit: 36310-3200-008
	Connector (Molex)
	54599-1019 (gray) 54599-1016 (black)

Encoder connector for HJ-KS/HJ-FS series



Applicable servo motor	Feature ^(Note 1)	Connector (TE Connectivity Ltd. Company)	Crimping tool (TE Connectivity Ltd. Company)	Applicable cable example
HJ-KS/HJ-FS	IP65	2174053-1	For ground clip: 1596970-1 For receptacle contact: 1596847-1	Wire size: 0.13 mm ² to 0.33 mm ² (AWG 26 to 22) Cable OD: 6.8 mm to 7.4 mm Wire example: Fluorine resin wire (Vinyl jacket cable TPE. SVP 70/0.08(AWG#22)-3P KB-2237-2 Bando Densen Co., Ltd. ^(Note 2) or an equivalent product)

Power connector for HJ-KS/HJ-FS series



Applicable servo motor	Feature ^(Note 1)	Connector (Japan Aviation Electronics Industry, Limited)	Crimping tool (Japan Aviation Electronics Industry, Limited)	Applicable cable example
HJ-KS/HJ-FS	IP65	Plug: KN4FT04SJ1-R Socket contact: ST-TMH-S-C1B-100-(A534G)	For contactor: CT170-14-TMH5B	Wire size: 0.3 mm ² to 0.75 mm ² (AWG 22 to 18) Cable OD: 5.3 mm to 6.5 mm Wire example: Fluorine resin wire (Vinyl jacket cable RMFES-A (CL3X) AWG 19, 4 cores Dyden Corporation ^(Note 3) or an equivalent product)

Electromagnetic brake connector for HJ-KS/HJ-FS series



Applicable servo motor	Feature ^(Note 1)	Connector (Japan Aviation Electronics Industry, Limited)	Crimping tool (Japan Aviation Electronics Industry, Limited)	Applicable cable example
HJ-KS/HJ-FS	IP65	Plug: JN4FT02SJ1-R Socket contact: ST-TMH-S-C1B-100-(A534G)	For contactor: CT170-14-TMH5B	Wire size: 0.3 mm ² to 0.5 mm ² (AWG 22 to 20) Cable OD: 3.6 mm to 4.8 mm Wire example: Fluorine resin wire (Vinyl jacket cable RMFES-A (CL3X) AWG 20, 2 cores Dyden Corporation ^(Note 3) or an equivalent product)

Notes: 1. The IP rating indicated is for the connector's protection against ingress of dust and water when coupled to a servo amplifier/servo motor. If the IP rating of the servo amplifier/servo motor differs from that of these connectors, overall IP rating depends on the lowest of all.

2. Contact Toa Electric Industrial Co., Ltd.

3. Contact Taisei Co., Ltd.

Configuration Example for MR-JE-AS (Note 2)

1 kW or smaller

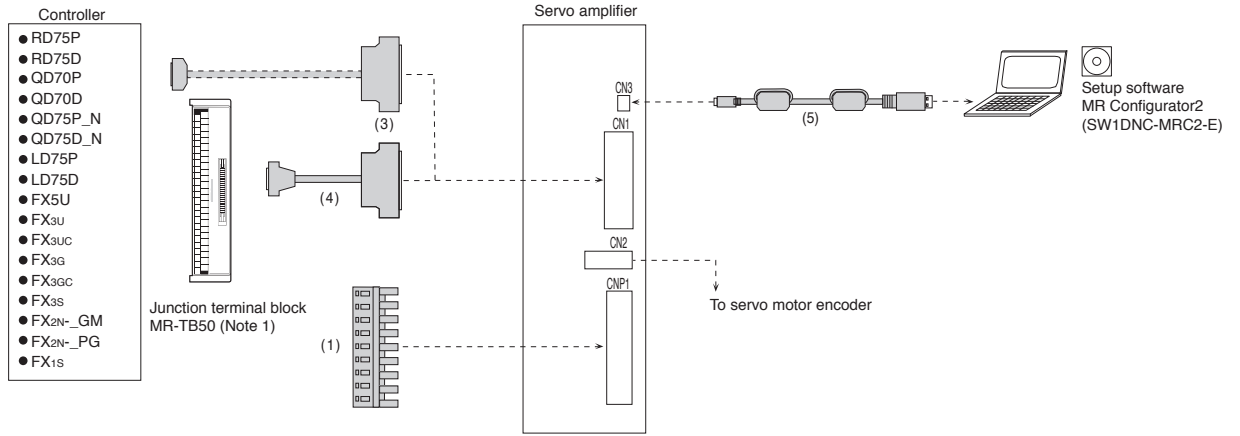

2 kW

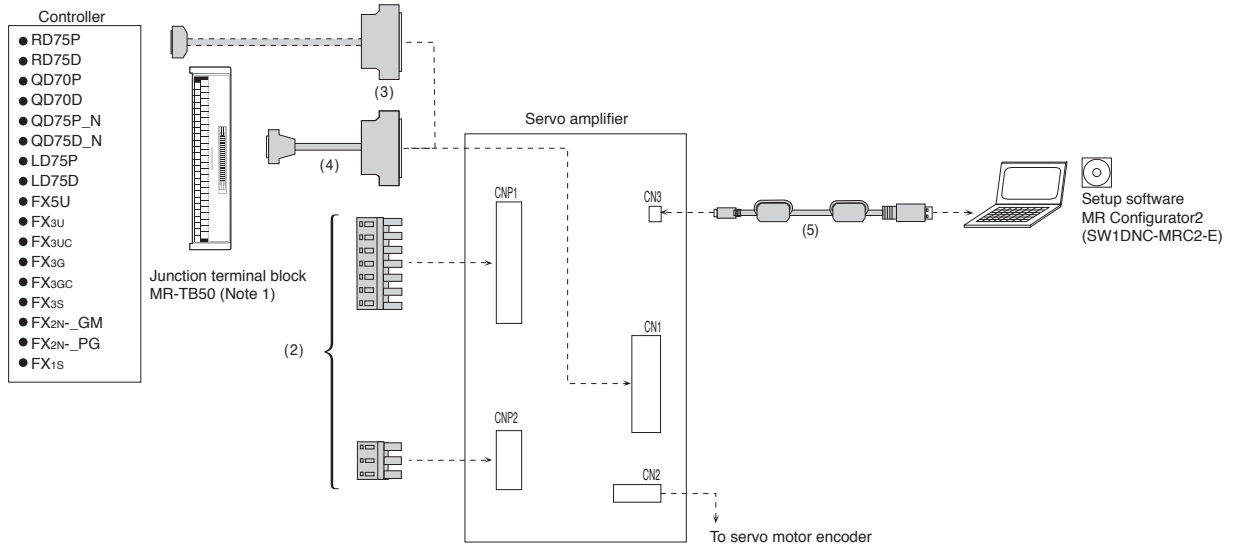











Notes: 1. Refer to "Junction Terminal Block" in this catalog.
 2. Cables drawn with dashed lines need to be fabricated by user. Refer to "MR-JE-AS HJ-KS_HJ-FS_ Instruction Manual" for fabricating the cables.

Options/Peripheral Equipment

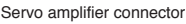

Cables and Connectors for MR-JE-AS



Refer to "Details of Optional Cables and Connectors for Servo Amplifiers" in this catalog for the detailed models.

	Item	Model	Cable length	IP rating	Application	Description
For CNP1	(1) Servo amplifier CNP1 power connector ^(Note 2) (insertion type)	MR-JECNP1-01	-	-	For MR-JE-100AS or smaller	  Applicable wire size ^(Note 1) : AWG 18 to 14 Insulator OD: up to 3.9 mm
For CNP1/CNP2	(2) Servo amplifier CNP1 power connector ^(Note 2) (insertion type)	MR-JECNP1-02	-	-	For MR-JE-200AS	  Applicable wire size ^(Note 1) : AWG 16 to 10 Insulator OD: up to 4.7 mm
	Servo amplifier CNP2 power connector ^(Note 2) (insertion type)	MR-JECNP2-02	-	-		 Applicable wire size ^(Note 1) : AWG 16 to 10 Insulator OD: up to 4.7 mm
For CN1	(3) Connector set	MR-J3CN1	-	-	For MR-JE-AS	 
	(4) Junction terminal block cable	MR-J2M-CN1TBL05M MR-J2M-CN1TBL1M	0.5 m 1 m	-	For connecting MR-JE-AS and MR-TB50	 
For CN3	(5) Personal computer communication cable (USB cable)	MR-J3USBCBL3M	3 m	-	For MR-JE-AS	 

Notes: 1. The wire size shows wiring specification of the connector. Refer to "Selection Example in HIV Wires for Servo Motors" in this catalog for examples of wire size selection.
 2. CNP1 and CNP2 connectors, and open tool are supplied with the servo amplifier.



Details of Optional Cables and Connectors for Servo Amplifiers

Model	CNP1 connector	Open tool
MR-JECNP1-01 (Note 2)	 09JFAT-SAXGDK-H5.0 (J.S.T. Mfg. Co., Ltd.)	 J-FAT-OT (N) (J.S.T. Mfg. Co., Ltd.)

Model	CNP1 connector	Open tool
MR-JECNP1-02 (Note 2)	 06(7-4)JFAT-SAXGFK-XL (J.S.T. Mfg. Co., Ltd.)	 J-FAT-OT-EXL (J.S.T. Mfg. Co., Ltd.)

Model	CNP2 connector
MR-JECNP2-02 (Note 2)	 03JFAT-SAXGFK-XL (J.S.T. Mfg. Co., Ltd.)

Model	Servo amplifier connector
MR-J3CN1	 Connector: 10150-3000PE Shell kit: 10350-52F0-008 (3M) or an equivalent product

Model	Junction terminal block connector	Servo amplifier connector
MR-J2M-CN1TBL_M	 Connector: D7950-B500FL (3M)	 Press bonding type (Note 1) Connector: 10150-6000EL Shell kit: 10350-3210-000 (3M)

Notes: 1. Solder type (connector: 10150-3000PE and shell kit: 10350-52F0-008) (3M) is also usable. Contact the manufacturer directly.
 2. CNP1 and CNP2 connectors, and an open tool are supplied with the servo amplifier.

Products on the Market for Servo Amplifiers

Application of connecting encoder junction cable

Unlisted lengths of cables between servo amplifier and servo motor, EMC cables, and special cables for connecting servo amplifier and servo motor with multiple cables are available. Please contact Mitsubishi Electric System & Service Co., Ltd. OVERSEAS BUSINESS PROMOTION DIVISION (Email: osb.webmaster@melsc.jp)

Example) Configuration using three encoder junction cables

- Replacing only the cable of the moving part in the cable chain is possible.
- Resetting after transporting a machine is easy because the servo amplifier side and the servo motor side can be separated.

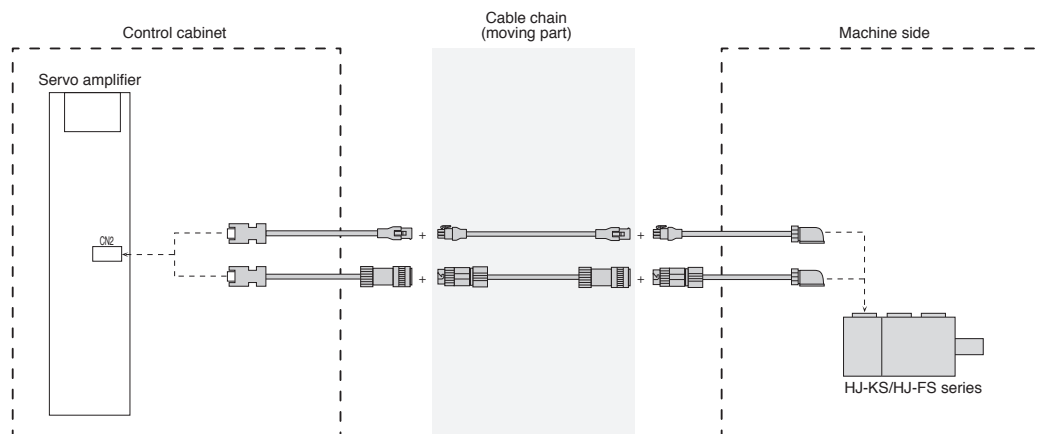

Regenerative Option

Servo amplifier model	Permissible regenerative power [W]					
	Built-in regenerative resistor	Regenerative option ^(Note 2)				
		MR-RB032	MR-RB12	MR-RB30	MR-RB32	MR-RB50 ^(Note 1)
		40 Ω	40 Ω	13 Ω	40 Ω	13 Ω
MR-JE-10AS	-	30	-	-	-	-
MR-JE-20AS	-	30	100	-	-	-
MR-JE-40AS	10	30	100	-	-	-
MR-JE-70AS	20	30	100	-	300	-
MR-JE-100AS	20	30	100	-	300	-
MR-JE-200AS	100	-	-	300	-	500

Notes: 1. Be sure to cool the unit forcibly with a cooling fan (92 mm × 92 mm, minimum air flow: 1.0 m³/min). The cooling fan must be prepared by user.

2. The power values in this table are resistor-generated powers, not rated powers.

* Cautions when connecting the regenerative option

1. The regenerative option causes a temperature rise of 100 °C or higher relative to the ambient temperature. Fully examine heat dissipation, installation position, wires used before installing the unit. Use flame-retardant wires or apply flame retardant on wires, and keep the wires clear of the unit.
2. Use twisted wires for connecting the regenerative option to the servo amplifier, and keep the wire length to a maximum of 5 m.
3. Use twisted wires for connecting a thermal sensor, and make sure that the sensor does not fail to work properly due to inducted noise.

Regenerative Option

Dimensions	[Unit: mm]	Connections									
<p>MR-RB032</p> <p>Terminal arrangement</p> <table border="1"> <tr><td>TE1</td></tr> <tr><td>G3</td></tr> <tr><td>G4</td></tr> <tr><td>P</td></tr> <tr><td>C</td></tr> </table> <p>Applicable wire size (Note 5): 0.2 mm² to 2.5 mm² (AWG 24 to 12) Mounting screw size: M5</p> <table border="1"> <thead> <tr> <th>Model</th> <th>Mass [kg]</th> </tr> </thead> <tbody> <tr> <td>MR-RB032</td> <td>0.5</td> </tr> </tbody> </table>	TE1	G3	G4	P	C	Model	Mass [kg]	MR-RB032	0.5		
TE1											
G3											
G4											
P											
C											
Model	Mass [kg]										
MR-RB032	0.5										
<p>MR-RB12</p> <p>Terminal arrangement</p> <table border="1"> <tr><td>TE1</td></tr> <tr><td>G3</td></tr> <tr><td>G4</td></tr> <tr><td>P</td></tr> <tr><td>C</td></tr> </table> <p>Applicable wire size (Note 5): 0.2 mm² to 2.5 mm² (AWG 24 to 12) Mounting screw size: M5</p> <table border="1"> <thead> <tr> <th>Model</th> <th>Mass [kg]</th> </tr> </thead> <tbody> <tr> <td>MR-RB12</td> <td>1.1</td> </tr> </tbody> </table>	TE1	G3	G4	P	C	Model	Mass [kg]	MR-RB12	1.1		
TE1											
G3											
G4											
P											
C											
Model	Mass [kg]										
MR-RB12	1.1										
<p>MR-RB30, MR-RB32</p> <p>Terminal arrangement</p> <table border="1"> <tr><td>P</td></tr> <tr><td>C</td></tr> <tr><td>G3</td></tr> <tr><td>G4</td></tr> </table> <p>Terminal screw size: M4 Mounting screw size: M6</p> <table border="1"> <thead> <tr> <th>Model</th> <th>Mass [kg]</th> </tr> </thead> <tbody> <tr> <td>MR-RB30</td> <td rowspan="2">2.9</td> </tr> <tr> <td>MR-RB32</td> </tr> </tbody> </table>	P	C	G3	G4	Model	Mass [kg]	MR-RB30	2.9	MR-RB32		<p>For 1 kW or smaller</p>
P											
C											
G3											
G4											
Model	Mass [kg]										
MR-RB30	2.9										
MR-RB32											
<p>MR-RB50</p> <p>Terminal arrangement</p> <table border="1"> <tr><td>P</td></tr> <tr><td>C</td></tr> <tr><td>G3</td></tr> <tr><td>G4</td></tr> </table> <p>Terminal screw size: M4 Mounting screw size: M6</p> <table border="1"> <thead> <tr> <th>Model</th> <th>Mass [kg]</th> </tr> </thead> <tbody> <tr> <td>MR-RB50</td> <td>5.6</td> </tr> </tbody> </table>	P	C	G3	G4	Model	Mass [kg]	MR-RB50	5.6		<p>For 2 kW</p>	
P											
C											
G3											
G4											
Model	Mass [kg]										
MR-RB50	5.6										

- Notes:
1. Create a sequence circuit that turns off the magnetic contactor when abnormal overheating occurs.
 2. When using MR-RB50, cool the unit forcibly with a cooling fan (92 mm × 92 mm, minimum air flow: 1.0 m³/min). The cooling fan must be prepared by user.
 3. When MR-RB30 or MR-RB32 is used, it may be necessary to cool the unit forcibly with a cooling fan (92 mm × 92 mm, minimum air flow: 1.0 m³/min), depending on the operating environment. Refer to "MR-JE-AS HJ-KS_HJ-FS_ Instruction Manual" for details. The cooling fan must be prepared by user.
 4. G3 and G4 terminals are thermal sensor. G3-G4 opens when the regenerative option overheats abnormally.
 5. The wire size shows wiring specification of the connector. Refer to "Wires, Molded-Case Circuit Breakers and Magnetic Contactors" in this catalog for examples of wire size selection.
 6. MR-JE-10AS/MR-JE-20AS do not have the built-in regenerative resistor.

Junction Terminal Block (MR-TB50)

Connect all signals via the junction terminal block.

Dimensions	[Unit: mm]
	Terminal screw size: M3.5 Applicable wire: 2 mm ² maximum Crimping terminal width: 7.2 mm or shorter Mounting screw size: M4

Radio Noise Filter (FR-BIF)

This filter suppresses noise from the power supply side of the servo amplifier, especially effective for the radio frequency bands of 10 MHz or lower. The FR-BIF is designed to be installed on the input side.

Dimensions	[Unit: mm]	Connections
		Do not use the FR-BIF on the output side of the servo amplifier. Wiring should be as short as possible, and grounding is required. Be sure to insulate the unused wire when using the FR-BIF with a 1-phase power supply.

Line Noise Filter (FR-BSF01)

This filter suppresses radio noise from the power supply side and the output side of the servo amplifier. The FR-BSF01 is also effective in suppressing high-frequency leakage current (zero-phase current), especially the range of 0.5 MHz and 5 MHz.

Dimensions	[Unit: mm]	Connections
		This line noise filter is installable on the wires for the power supply (L1, L2, and L3) to the servo amplifier and the power supply (U, V, and W) to the servo motor. Pass each of the wires through the line noise filter equal times in a same direction. For the power supply, the effect of the filter rises as the number of passes increases, but generally four passes would be appropriate. For the servo motor power, passes must be four times or less. Do not pass the grounding wire through the filter. Otherwise, the effect of the filter is reduced. Wind the wires to pass through the filter as the required number of passes as shown in Fig. 1. If the wires are too thick to wind, use two or more filters to have the required number of passes as shown in Fig. 2. Place the line noise filters as close to the servo amplifier as possible for their best performance.
		<div style="display: flex; justify-content: space-around;"> <div style="text-align: center;"> <p>Fig. 1</p> </div> <div style="text-align: center;"> <p>Fig. 2</p> </div> </div>

Data Line Filter

This filter is effective in preventing noise when attached to the pulse output cable of the pulse train output controller or the motor encoder cable.

Example) ESD-SR-250 (manufactured by NEC TOKIN Corporation)
 ZCAT3035-1330 (manufactured by TDK)
 GRFC-13 (manufactured by Kitagawa Industries Co., Ltd.)

Surge Killer

Attach surge killers to AC relays and AC valves around the servo amplifier. Attach diodes to DC relays and DC valves.

Example) Surge killer: CR-50500 (manufactured by Okaya Electric Industries Co., Ltd.)
 Diode: A diode with breakdown voltage four or more times greater than the relay drive voltage, and with current capacity two or more times greater than the relay drive current.

Options/Peripheral Equipment

EMC Filter

The following filters are recommended as a filter compliant with the EMC directive for the power supply of the servo amplifier.

Servo amplifier model	EMC filter model ^(Note 2)	Rated current [A]	Rated voltage [V AC]	Fig.
MR-JE-10AS to 100AS	HF3010A-UN ^(Note 1)	10	250	A
MR-JE-200AS	HF3030A-UN ^(Note 1)	30	250	B

Notes: 1. Manufactured by Soshin Electric Co., Ltd.

A surge protector is separately required to use this EMC filter. Refer to "EMC Installation Guidelines."

2. When using the EMC filter, install one EMC filter for each servo amplifier.

	Dimensions [Unit: mm]	Connections						
A	<p>HF3010A-UN</p> <table border="1"> <thead> <tr> <th>Model</th> <th>Leakage current [mA]</th> <th>Mass [kg]</th> </tr> </thead> <tbody> <tr> <td>HF3010A-UN</td> <td>5</td> <td>3.5</td> </tr> </tbody> </table>	Model	Leakage current [mA]	Mass [kg]	HF3010A-UN	5	3.5	<p>For 3-phase 200 V AC</p> <p>For 1-phase 200 V AC (1 kW or smaller)</p>
Model	Leakage current [mA]	Mass [kg]						
HF3010A-UN	5	3.5						
B	<p>HF3030A-UN</p> <table border="1"> <thead> <tr> <th>Model</th> <th>Leakage current [mA]</th> <th>Mass [kg]</th> </tr> </thead> <tbody> <tr> <td>HF3030A-UN</td> <td>5</td> <td>5.5</td> </tr> </tbody> </table>	Model	Leakage current [mA]	Mass [kg]	HF3030A-UN	5	5.5	<p>For 1-phase 200 V AC (2 kW)</p>
Model	Leakage current [mA]	Mass [kg]						
HF3030A-UN	5	5.5						

Power Factor Improving AC Reactor (FR-HAL)

This boosts the power factor of servo amplifier and reduces the power supply capacity.

Servo amplifier model	Power factor improving AC reactor model ^(Note 1)	Fig.
MR-JE-10AS	FR-HAL-0.4K	A
MR-JE-20AS		
MR-JE-40AS	FR-HAL-0.75K	
MR-JE-70AS	FR-HAL-1.5K	
MR-JE-100AS (3-phase power supply input)	FR-HAL-2.2K	B
MR-JE-100AS (1-phase power supply input)	FR-HAL-3.7K	
MR-JE-200AS (3-phase power supply input)	FR-HAL-3.7K	
MR-JE-200AS (1-phase power supply input)	FR-HAL-5.5K	

Notes: 1. When using the power factor improving AC reactor, install one reactor for each servo amplifier.

Dimensions		[Unit: mm]	Connections																																																			
A		<table border="1"> <thead> <tr> <th rowspan="2">Model</th> <th colspan="7">Variable dimensions</th> </tr> <tr> <th>W</th> <th>W1</th> <th>H</th> <th>D</th> <th>D1</th> <th>D2</th> <th>d</th> </tr> </thead> <tbody> <tr> <td>FR-HAL-0.4K</td> <td>104±2</td> <td>84</td> <td>99</td> <td>72</td> <td>51</td> <td>40</td> <td>M5</td> </tr> <tr> <td>FR-HAL-0.75K</td> <td>104±2</td> <td>84</td> <td>99</td> <td>74</td> <td>56</td> <td>44</td> <td>M5</td> </tr> <tr> <td>FR-HAL-1.5K</td> <td>104±2</td> <td>84</td> <td>99</td> <td>77</td> <td>61</td> <td>50</td> <td>M5</td> </tr> </tbody> </table> <table border="1"> <thead> <tr> <th>Model</th> <th>Mass [kg]</th> <th>Terminal screw size</th> </tr> </thead> <tbody> <tr> <td>FR-HAL-0.4K</td> <td>0.6</td> <td>M4</td> </tr> <tr> <td>FR-HAL-0.75K</td> <td>0.8</td> <td>M4</td> </tr> <tr> <td>FR-HAL-1.5K</td> <td>1.1</td> <td>M4</td> </tr> </tbody> </table>	Model	Variable dimensions							W	W1	H	D	D1	D2	d	FR-HAL-0.4K	104±2	84	99	72	51	40	M5	FR-HAL-0.75K	104±2	84	99	74	56	44	M5	FR-HAL-1.5K	104±2	84	99	77	61	50	M5	Model	Mass [kg]	Terminal screw size	FR-HAL-0.4K	0.6	M4	FR-HAL-0.75K	0.8	M4	FR-HAL-1.5K	1.1	M4	<p>For 3-phase 200 V AC</p>
				Model	Variable dimensions																																																	
W	W1	H	D		D1	D2	d																																															
FR-HAL-0.4K	104±2	84	99	72	51	40	M5																																															
FR-HAL-0.75K	104±2	84	99	74	56	44	M5																																															
FR-HAL-1.5K	104±2	84	99	77	61	50	M5																																															
Model	Mass [kg]	Terminal screw size																																																				
FR-HAL-0.4K	0.6	M4																																																				
FR-HAL-0.75K	0.8	M4																																																				
FR-HAL-1.5K	1.1	M4																																																				
B		<table border="1"> <thead> <tr> <th rowspan="2">Model</th> <th colspan="7">Variable dimensions</th> </tr> <tr> <th>W</th> <th>W1</th> <th>H</th> <th>D</th> <th>D1</th> <th>D2</th> <th>d</th> </tr> </thead> <tbody> <tr> <td>FR-HAL-2.2K</td> <td>115</td> <td>40</td> <td>115</td> <td>77</td> <td>71</td> <td>57</td> <td>M6</td> </tr> <tr> <td>FR-HAL-3.7K</td> <td>115</td> <td>40</td> <td>115</td> <td>83</td> <td>81</td> <td>67</td> <td>M6</td> </tr> <tr> <td>FR-HAL-5.5K</td> <td>115</td> <td>40</td> <td>115</td> <td>83</td> <td>81</td> <td>67</td> <td>M6</td> </tr> </tbody> </table> <table border="1"> <thead> <tr> <th>Model</th> <th>Mass [kg]</th> <th>Terminal screw size</th> </tr> </thead> <tbody> <tr> <td>FR-HAL-2.2K</td> <td>1.5</td> <td>M4</td> </tr> <tr> <td>FR-HAL-3.7K</td> <td>2.2</td> <td>M4</td> </tr> <tr> <td>FR-HAL-5.5K</td> <td>2.3</td> <td>M4</td> </tr> </tbody> </table>	Model	Variable dimensions							W	W1	H	D	D1	D2	d	FR-HAL-2.2K	115	40	115	77	71	57	M6	FR-HAL-3.7K	115	40	115	83	81	67	M6	FR-HAL-5.5K	115	40	115	83	81	67	M6	Model	Mass [kg]	Terminal screw size	FR-HAL-2.2K	1.5	M4	FR-HAL-3.7K	2.2	M4	FR-HAL-5.5K	2.3	M4	<p>For 1-phase 200 V AC (1 kW or smaller)</p>
				Model	Variable dimensions																																																	
W	W1	H	D		D1	D2	d																																															
FR-HAL-2.2K	115	40	115	77	71	57	M6																																															
FR-HAL-3.7K	115	40	115	83	81	67	M6																																															
FR-HAL-5.5K	115	40	115	83	81	67	M6																																															
Model	Mass [kg]	Terminal screw size																																																				
FR-HAL-2.2K	1.5	M4																																																				
FR-HAL-3.7K	2.2	M4																																																				
FR-HAL-5.5K	2.3	M4																																																				
			<p>For 1-phase 200 V AC (2 kW)</p>																																																			

Notes: 1. Use this mounting hole for grounding.

2. This indicates the maximum dimension. The dimension varies depending on the bending degree of the input/output line.

Options/Peripheral Equipment

Servo Support Software

Capacity selection software (MRZJW3-MOTSZ111E)

Specifications

Item	Description	
Types of machine component	Horizontal ball screws, vertical ball screws, rack and pinions, roll feeds, rotating tables, carts, elevators, conveyors, other (direct inertia input) devices	
Output of results	Item	Servo amplifier, servo motor, regenerative option, moment of inertia of load, load to motor inertia ratio, peak torque, peak torque ratio, effective torque, effective torque ratio, regenerative power, regenerative power ratio
	Printing	Prints entered specifications, operating pattern, calculation process, graph of selection process feed speed (or motor speed) and torque, and sizing results.
	Data saving	Entered specifications, operating patterns and sizing results are saved with a file name.
Moment of inertia calculation function	Cylinder, square block, variable speed, linear movement, hanging, conical, conical base	

System requirements

IBM PC/AT compatible model running with the following requirements.

Components	Capacity selection software (MRZJW3-MOTSZ111E) ^(Note 1)	
Personal computer ^(Note 2)	OS ^(Note 3) (English version)	Microsoft® Windows® 8.1 Enterprise Operating System Microsoft® Windows® 8.1 Pro Operating System Microsoft® Windows® 8.1 Operating System Microsoft® Windows® 8 Enterprise Operating System Microsoft® Windows® 8 Pro Operating System Microsoft® Windows® 8 Operating System Microsoft® Windows® 7 Enterprise Operating System Microsoft® Windows® 7 Ultimate Operating System Microsoft® Windows® 7 Professional Operating System Microsoft® Windows® 7 Home Premium Operating System Microsoft® Windows® 7 Starter Operating System Microsoft® Windows Vista® Enterprise Operating System Microsoft® Windows Vista® Ultimate Operating System Microsoft® Windows Vista® Business Operating System Microsoft® Windows Vista® Home Premium Operating System Microsoft® Windows Vista® Home Basic Operating System Microsoft® Windows® XP Professional Operating System Microsoft® Windows® XP Home Edition Operating System Microsoft® Windows® 2000 Professional Operating System Microsoft® Windows® Millennium Edition Operating System Microsoft® Windows® 98 Second Edition Operating System Microsoft® Windows® 98 Operating System
	CPU	Pentium® 133 MHz or more (Windows® 98, Windows® 2000) Pentium® 150 MHz or more (Windows® Millennium Edition) Pentium® 300 MHz or more (Windows® XP) 1 GHz or more 32-bit (x86) processor (Windows Vista®) 1 GHz or more 32-bit (x86) or 64-bit (x64) processor (Windows® 7, Windows® 8, Windows® 8.1)
	Memory	24 MB or more (Windows® 98) 32 MB or more (Windows® Millennium Edition, Windows® 2000) 128 MB or more (Windows® XP) 1 GB or more (Windows Vista®, Windows® 7, Windows® 8, Windows® 8.1)
	Free hard disk space	40 MB or more
Browser	Windows® Internet Explorer® 4.0 or later	
Monitor	Resolution 800 × 600 or more, 16-bit high color, Compatible with above personal computers.	
Keyboard	Compatible with above personal computers.	
Mouse	Compatible with above personal computers.	
Printer	Compatible with above personal computers.	
Communication cable	Not required	

Notes: 1. Software version D4 or later is compatible with MR-JE-AS.

2. This software may not run correctly, depending on a personal computer being used.

3. For 64-bit operating system, this software is compatible with Windows® 7 or later.



Servo Support Software

MR Configurator2 (SW1DNC-MRC2-E)

MR Configurator2 can be obtained by either of the following:

- Purchase MR Configurator2 alone.
- Purchase MT Works2: MR Configurator2 is included in MT Works2 with software version 1.34L or later.
- Download MR Configurator2: If you have GX Works2 or MT Works2 with software version earlier than 1.34L, you can download MR Configurator2 from website free of charge.

Specifications

Item	Description
Project	New/Open/Save/Save As/Delete Project, System Setting, Print
Parameter	Parameter Setting, Axis Name Setting
Monitor	Display All, I/O Monitor, Graph
Diagnosis	Alarm Display, Alarm Onset Data, No Motor Rotation, System Configuration, Life Diagnosis
Test Operation	JOG Operation, Positioning Operation, Motor-Less Operation, DO Forced Output, Program Operation, Test Operation Information
Adjustment	One-touch Tuning, Tuning, Machine Analyzer
Others	Servo Assistant, Update Parameter Setting Range, Switch Display Language, Help

System requirements

IBM PC/AT compatible model running with the following requirements.

Components		MR Configurator2 ^(Note 3)
Personal computer ^(Note 1)	OS ^(Note 2)	Microsoft® Windows® 10 Enterprise Operating System/Pro Operating System/Home Operating System Microsoft® Windows® 8.1 Enterprise Operating System/Pro Operating System/Operating System Microsoft® Windows® 8 Enterprise Operating System/Pro Operating System/Operating System Microsoft® Windows® 7 Enterprise Operating System/Ultimate Operating System/Professional Operating System/Home Premium Operating System/Starter Operating System Microsoft® Windows Vista® Enterprise Operating System/Ultimate Operating System/Business Operating System/Home Premium Operating System/Home Basic Operating System Microsoft® Windows® XP Professional Operating System, Service Pack3/Home Edition Operating System, Service Pack3
	CPU (recommended)	Desktop PC: Intel® Celeron® processor 2.8 GHz or more Laptop PC: Intel® Pentium® M processor 1.7 GHz or more
	Memory (recommended)	512 MB or more (32-bit OS), 1 GB or more (64-bit OS)
	Free hard disk space	1 GB or more
	Communication interface	Use USB port
	Browser	Windows® Internet Explorer® 4.0 or later
Monitor	Resolution 1024 × 768 or more, 16-bit high color, Compatible with above personal computers.	
Keyboard	Compatible with above personal computers.	
Mouse	Compatible with above personal computers.	
Printer	Compatible with above personal computers.	
Communication cable	MR-J3USBCBL3M	

Notes: 1. This software may not run correctly, depending on a personal computer being used.

2. For 64-bit operating system, this software is compatible with Windows® 7 or later.

3. Software version 1.52E or later is compatible with MR-JE-AS.

MEMO



4

Low-Voltage Switchgear/Wires

Features of Low-Voltage Switchgear.....	4-2
Wires, Molded-Case Circuit Breakers and Magnetic Contactors	4-5
Selection Example in HIV Wires for Servo Motors	4-5

Low-Voltage Switchgear/Wires

Mitsubishi Molded Case Circuit Breakers and Earth Leakage Circuit Breakers WS-V Series

"WS-V Series" is the new circuit breakers that have a lot of superior aspects such as higher breaking capacity, design for easy use, standardization of accessory parts, and compliance to the global standards.

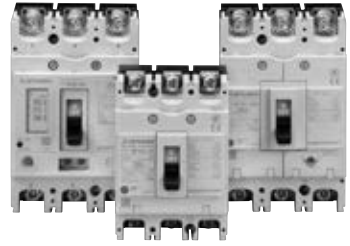

Features

Technologies based on long years of experience are brought together to achieve improved performance

The new circuit breaking technology "Expanded ISTAC" has improved the current-limiting performance and upgraded the overall breaking capacity. Expansion of the conductor under the stator shortens the contact parting time of the mover as compared to the conventional ISTAC structure. The current-limiting performance has been improved remarkably. (The maximum peak current value has been reduced by approx. 10%.)

Compact design for ease of use

The thermal adjustable circuit breakers and electronic circuit breakers are smaller.

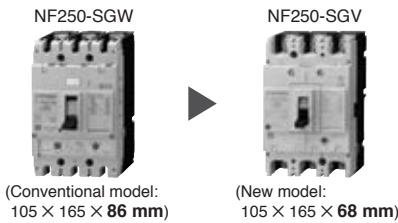

Volume ratio 79%
(Compared with our conventional models)

Types of internal accessories are reduced from 3 types to 1 type
Standardization of internal accessories contributes to a reduction of stock and delivery time.

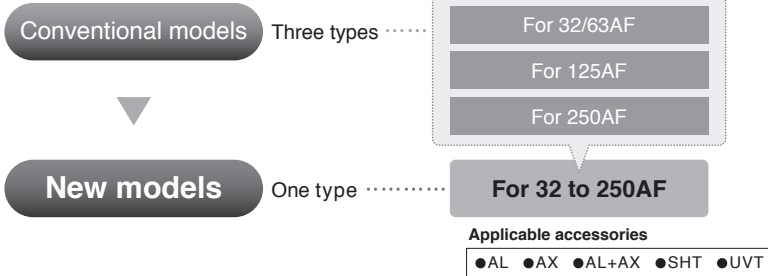

New circuit breaking technology (Expanded ISTAC)

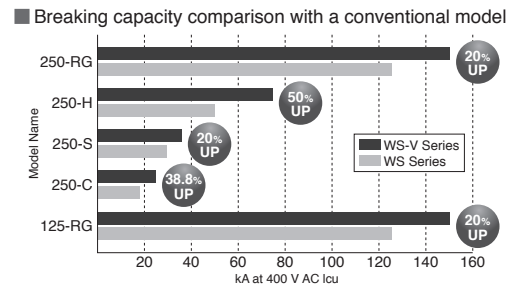
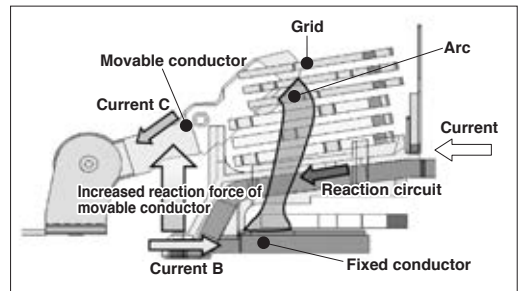

Lineup of UL 489 listed circuit breakers with 54 mm width "Small Fit" **F** Style

The compact breakers contribute to a size reduction of machines, and IEC 35 mm rail mounting is standard.

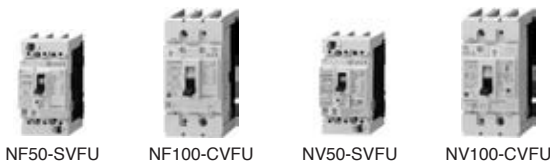

For security and standard compliance of machines, F-type and V-type operating handles are available for breakers with 54 mm width.

Lineup of UL 489 listed circuit breakers for 480 V AC "High Performance"

The breaking capacity has been improved to satisfy the request for SCCR upgrading.

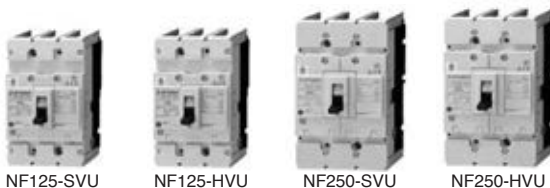

Breaking capacity of UL 489 listed circuit breakers for 480 V AC (UL 489)

- NF125-SVU/NV125-SVU: 30 kA
- NF125-HVU/NV125-HVU: 50 kA
- NF250-SVU/NV250-SVU: 35 kA
- NF250-HVU/NV250-HVU: 50 kA

Mitsubishi Magnetic Motor Starters and Magnetic Contactors MS-T Series

MS-T series is newly released!

The MS-T series is smaller than ever, enabling more compact control panel. The MS-T series is suitable for MELSERVO-J4 series as well as other Mitsubishi FA equipment. In addition, the MS-T conforms to a variety of global standards, supporting the global use.



S-T10

Features

Compact

Just 36 mm wide for 10 A-frame type!

General-purpose magnetic contactor with smallest width* in the industry.

The width of MS-T series is reduced by 32% as compared to the prior MS-N series, enabling a more compact panel.

*Based on Mitsubishi Electric research as of August 2016 in the general-purpose magnetic contactor industry for 10 A-frame class.

[Unit: mm]

Frame size		11 A	13 A		20 A	25 A
MS-N series	Front view					
		S-N10	S-N11 (Auxiliary 1-pole)	S-N12 (Auxiliary 2-pole)	S-N20	S-N25
New MS-T series	Front view					
		S-T10	S-T12 (Auxiliary 2-pole)	S-T20	S-T25	

Frame size		35 A	50 A	65 A	80 A	100 A
MS-N series	Front view					
		S-N35	S-N50	S-N65	S-N80	S-N95
New MS-T series	Front view					
		S-T35	S-T50	S-T65	S-T80	S-T100

Standardization

Covers provided as standard equipment (Coverage: under 50 AF)

Terminal cover and auxiliary contact unit covers are provided as standard equipment. Not only ensuring your safety, but also saving you time and cost of selecting and purchasing the covers separately.

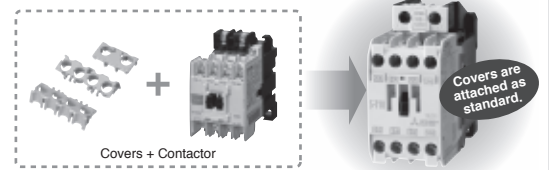

Wide-ranged operation coil rating (Coverage: under 35AF)

The prior series had 14 types of the operation coil rating. Owing to the wide-ranged operation coil rating, the number of the rating types for the MS-T series is reduced to half, making it easier to select as compared to the prior model.

Consolidating the number of the produced coils type allows not just the reduction of customer storage, but also shortening of delivery time.

Coil designation	Rated voltage [V]		Coil designation	Rated voltage [V]
	50 Hz	60 Hz		50 Hz/60 Hz
AC12 V	12	12	AC12 V	12
AC24 V	24	24	AC24 V	24
AC48 V	48 to 50	48 to 50	AC48 V	48 to 50
AC100 V	100	100 to 110	AC100 V	100 to 127
AC120 V	110 to 120	115 to 120	AC200 V	200 to 240
AC127 V	125 to 127	127	AC300 V	260 to 300
AC200 V	200	200 to 220	AC400 V	380 to 440
AC220 V	208 to 220	220	AC500 V	460 to 550
AC230 V	220 to 240	230 to 240		
AC260 V	240 to 260	260 to 280		
AC380 V	346 to 380	380		
AC400 V	380 to 415	400 to 440		
AC440 V	415 to 440	460 to 480		
AC500 V	500	500 to 550		

* The conventional eight types are available for the 50A and larger frames.

Servo Amplifiers

Servo Motors

Options/Peripheral Equipment

LVSWires

Product List

Cautions

Low-Voltage Switchgear/Wires

Capable of direct drive with transistor output of PLC, etc.

Capable of direct drive with the rated transistor output of 24V DC and 0.1 A, thanks to high-efficiency polarized electromagnet.

Reduced coil power consumption

DC operated type realize low power consumption.

	Traditional MS-N series	New MS-T series	Reduced rate
13 A Frame* ¹ (Coil: DC 12/24 V)	7 W	2.2 W	69%
20 A Frame* ¹ (Coil: DC 12/24 V)	9 W	2.2 W	76%
32 A Frame* ¹ (Coil: DC 12/24 V)	-	2.2 W	-
50 A Frame* ²	18 W	9 W	50%
80 A Frame* ²	24 W	18 W	25%

*1. Consumption electric amounts of DC 48 V-220 V are 3.3W.

*2. The power consumption is average value. These are almost same for coils other than 100 V DC.

Safety & Quality

No touch safety (Coverage: under 50 AF)

The integrated terminal covers offer various benefits not to mention added protection against electric shock through secure finger protection. This is available not only on Magnetic Contactors but also on Thermal Overload Relays, Contactor Relays and Auxiliary Contact Units.

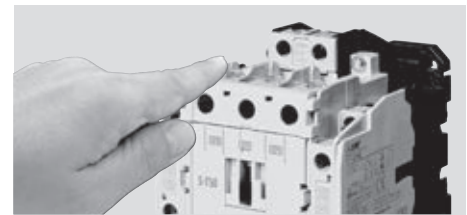

MS-T Series complies with DIN EN 50274/VDE 0660 Teil 514 for "Finger safe (prevention of finger contact)."

A light touch

The MS-T Series' auxiliary contacts can operate with load as light as 20 V 3 mA making it suitable for direct control/operation from a PLC output.



Smart wiring (Coverage: Under 50 AF)

The integrated terminal covers have an additional benefit in that they act as a guide to improve wiring efficiency but also retain the terminal screw in place: no mislaying the screw, no dropping it or having trouble reinserting it into the terminal block just fast efficient wiring. Fast wiring terminals (model name with suffix "BC") are also available to further improve wiring efficiency, workability and hence productivity.

Image of Fast wiring terminals (BC type)

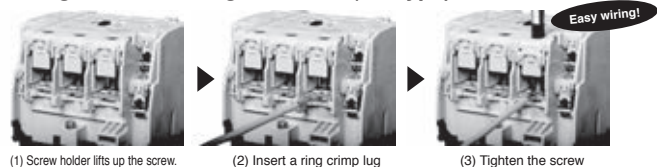

Global Standard

Conforms to various global standards (Coverage: All)

Not only major global standards such as IEC, JIS, UL, CE, and CCC but also ship standards and other country standards are planned to be certified.

Ⓞ : Compliant as standard

Model	Applicable Standard				Safety Standard		EC Directive	Certification Body	CCC
	IEC	JIS	DIN/VDE	BS/EN	UL	CSA	CE Marking	TÜV	GB
	International	Japan	Germany	England Europe	U.S.A	Canada	Europe	Germany	China
S-T10 to S-T100 TH-T18KP to TH-T100KP	Ⓞ	Ⓞ	Ⓞ	Ⓞ	Ⓞ	Ⓞ	Ⓞ	Ⓞ ₁	Ⓞ

*1. The Motor Starters will be certified under each type name of the Magnetic contactors and the Thermal Overload Relays on the condition that the Magnetic contactors and the Thermal Overload Relays are used in combination.

Wires, Molded-Case Circuit Breakers and Magnetic Contactors

The following are examples of wire sizes when 600 V grade heat-resistant polyvinyl chloride insulated wires (HIV wires) are used. The wire size for U, V, W, and \ominus varies depending on the servo motor. Refer to "Selection Example in HIV Wires for Servo Motors" in this catalog for details on wires for each servo motor.

Servo amplifier model	Molded-case circuit breaker <small>(Note 4, 5, 6)</small>	Magnetic contactor <small>(Note 2, 5)</small>	Wire size [mm ²] <small>(Note 4)</small>		
			L1, L2, L3, \ominus	P+, C	U, V, W, \ominus
MR-JE-10AS	30 A frame 5 A (30 A frame 5 A)	S-T10	2 (AWG 14)	2 (AWG 14) <small>(Note 1)</small>	AWG 18 to 14 <small>(Note 3)</small>
MR-JE-20AS	30 A frame 5 A (30 A frame 5 A)	S-T10			
MR-JE-40AS	30 A frame 10 A (30 A frame 5 A)	S-T10			
MR-JE-70AS	30 A frame 15 A (30 A frame 10 A)	S-T10			
MR-JE-100AS (3-phase power supply input)	30 A frame 15 A (30 A frame 10 A)	S-T10			
MR-JE-100AS (1-phase power supply input)	30 A frame 15 A (30 A frame 15 A)	S-T10			
MR-JE-200AS (3-phase power supply input)	30 A frame 20 A (30 A frame 20 A)	S-T21	3.5 (AWG 12)		AWG 16 to 10 <small>(Note 3)</small>
MR-JE-200AS (1-phase power supply input)	30 A frame 20 A (30 A frame 20 A)	S-T21			

- Notes: 1. Keep the wire length to the regenerative option within 5 m.
 2. Be sure to use a magnetic contactor with an operation delay time of 80 ms or less. The operation delay time is the time interval from current being applied to the coil until closure of contacts.
 3. The wire size shows applicable size for the servo amplifier connector.
 4. When complying with IEC/EN/UL/CSA standard, refer to "MELSERVO-JE Instructions and Cautions for Safe Use of AC Servos" enclosed with the servo amplifier. When using a power improving reactor, use a molded-case circuit breaker listed in the brackets.
 5. Install one molded-case circuit breaker and one magnetic contactor for each servo amplifier.
 6. Use a molded-case circuit breaker having the operation characteristics equal to or higher than Mitsubishi general-purpose products.

Selection Example in HIV Wires for Servo Motors

The following are examples of wire sizes when 600 V grade heat-resistant polyvinyl chloride insulated wires (HIV wires) with a length of 30 m are used.

Servo motor model	Wire size [mm ²]	
	For power and grounding (U, V, W, \ominus) (general environment)	For electromagnetic brake (B1, B2)
HJ-KS13(B), HJ-KS23(B), HJ-KS43(B), HJ-KS73(B), HJ-KS103A(B), HJ-KS103(B), HJ-KS153(B), HJ-KS203(B), HJ-KS102(B), HJ-KS152(B), HJ-KS202(B), HJ-FS23(B), HJ-FS43(B), HJ-FS73(B), HJ-FS103A(B)	0.75 (AWG 18) <small>(Note 1, 2)</small>	0.5 (AWG 20) <small>(Note 3, 4)</small>

- Notes: 1. Use a fluorine resin wire of 0.75 mm² (AWG 18) for wiring to the servo motor power connector.
 2. This size is applicable for wiring length of 10 m or shorter. For over 10 m, use MR-PWS2CBL03M-A_-L and extend it with HIV wire of 2 mm² (AWG 14).
 3. Use a fluorine resin wire of 0.5 mm² (AWG 20) when connecting to servo motor electromagnetic brake connector.
 4. This size is applicable for wiring length of 10 m or shorter. For over 10 m, extend the wire with HIV wire of 1.25 mm² (AWG 16).

Servo Amplifiers
 Servo Motors
 Options/Peripheral Equipment
 LV/SM/Wires
 Product List
 Cautions

Product list

Servo amplifiers

Item	Model	Rated output	Power supply
MR-JE-AS	MR-JE-10AS	0.1 kW	3-phase or 1-phase 200 V AC to 240 V AC
	MR-JE-20AS	0.2 kW	3-phase or 1-phase 200 V AC to 240 V AC
	MR-JE-40AS	0.4 kW	3-phase or 1-phase 200 V AC to 240 V AC
	MR-JE-70AS	0.75 kW	3-phase or 1-phase 200 V AC to 240 V AC
	MR-JE-100AS	1.0 kW	3-phase or 1-phase 200 V AC to 240 V AC
	MR-JE-200AS	2.0 kW	3-phase or 1-phase 200 V AC to 240 V AC

Servo motors

Item	Model	Rated output	Rated speed
HJ-KS 3000 r/min series Without electromagnetic brake/ With oil seal	HJ-KS13J	0.1 kW	3000 r/min
	HJ-KS23J	0.2 kW	3000 r/min
	HJ-KS43J	0.4 kW	3000 r/min
	HJ-KS73J	0.75 kW	3000 r/min
	HJ-KS103AJ	1.0 kW	3000 r/min
	HJ-KS103J	1.0 kW	3000 r/min
	HJ-KS153J	1.5 kW	3000 r/min
	HJ-KS203J	2.0 kW	3000 r/min
HJ-KS 3000 r/min series Without electromagnetic brake/ Without oil seal	HJ-KS13	0.1 kW	3000 r/min
	HJ-KS23	0.2 kW	3000 r/min
	HJ-KS43	0.4 kW	3000 r/min
	HJ-KS73	0.75 kW	3000 r/min
	HJ-KS103A	1.0 kW	3000 r/min
	HJ-KS103	1.0 kW	3000 r/min
	HJ-KS153	1.5 kW	3000 r/min
HJ-KS203	2.0 kW	3000 r/min	
HJ-KS 3000 r/min series With electromagnetic brake/ With oil seal	HJ-KS13BJ	0.1 kW	3000 r/min
	HJ-KS23BJ	0.2 kW	3000 r/min
	HJ-KS43BJ	0.4 kW	3000 r/min
	HJ-KS73BJ	0.75 kW	3000 r/min
	HJ-KS103ABJ	1.0 kW	3000 r/min
	HJ-KS103BJ	1.0 kW	3000 r/min
	HJ-KS153BJ	1.5 kW	3000 r/min
HJ-KS203BJ	2.0 kW	3000 r/min	
HJ-KS 3000 r/min series With electromagnetic brake/ Without oil seal	HJ-KS13B	0.1 kW	3000 r/min
	HJ-KS23B	0.2 kW	3000 r/min
	HJ-KS43B	0.4 kW	3000 r/min
	HJ-KS73B	0.75 kW	3000 r/min
	HJ-KS103AB	1.0 kW	3000 r/min
	HJ-KS103B	1.0 kW	3000 r/min
	HJ-KS153B	1.5 kW	3000 r/min
HJ-KS203B	2.0 kW	3000 r/min	
HJ-KS 2000 r/min series Without electromagnetic brake/ With oil seal	HJ-KS102J	1.0 kW	2000 r/min
	HJ-KS152J	1.5 kW	2000 r/min
	HJ-KS202J	2.0 kW	2000 r/min
HJ-KS 2000 r/min series Without electromagnetic brake/ Without oil seal	HJ-KS102	1.0 kW	2000 r/min
	HJ-KS152	1.5 kW	2000 r/min
	HJ-KS202	2.0 kW	2000 r/min
HJ-KS 2000 r/min series With electromagnetic brake/ With oil seal	HJ-KS102BJ	1.0 kW	2000 r/min
	HJ-KS152BJ	1.5 kW	2000 r/min
	HJ-KS202BJ	2.0 kW	2000 r/min
HJ-KS 2000 r/min series With electromagnetic brake/ Without oil seal	HJ-KS102B	1.0 kW	2000 r/min
	HJ-KS152B	1.5 kW	2000 r/min
	HJ-KS202B	2.0 kW	2000 r/min

Servo motors

Item	Model	Rated output	Rated speed
HJ-FS series Without electromagnetic brake/ With oil seal	HJ-FS23J	0.2 kW	3000 r/min
	HJ-FS43J	0.4 kW	3000 r/min
	HJ-FS73J	0.75 kW	3000 r/min
	HJ-FS103AJ	1.0 kW	3000 r/min
HJ-FS series Without electromagnetic brake/ Without oil seal	HJ-FS23	0.2 kW	3000 r/min
	HJ-FS43	0.4 kW	3000 r/min
	HJ-FS73	0.75 kW	3000 r/min
	HJ-FS103A	1.0 kW	3000 r/min
HJ-FS series With electromagnetic brake/ With oil seal	HJ-FS23BJ	0.2 kW	3000 r/min
	HJ-FS43BJ	0.4 kW	3000 r/min
	HJ-FS73BJ	0.75 kW	3000 r/min
	HJ-FS103ABJ	1.0 kW	3000 r/min
HJ-FS series With electromagnetic brake/ Without oil seal	HJ-FS23B	0.2 kW	3000 r/min
	HJ-FS43B	0.4 kW	3000 r/min
	HJ-FS73B	0.75 kW	3000 r/min
	HJ-FS103AB	1.0 kW	3000 r/min

Servo Amplifiers

Servo Motors

Options/Peripheral Equipment

LVS/Wires

Product List

Cautions

Product list

Encoder cables/Junction cables

Item	Model	Length	Bending life	IP rating	Application
Encoder cable (load-side lead)	MR-J3ENCBL2M-A1-H	2 m	Long bending life	IP65	For HJ-KS/HJ-FS (direct connection type)
	MR-J3ENCBL5M-A1-H	5 m	Long bending life	IP65	For HJ-KS/HJ-FS (direct connection type)
	MR-J3ENCBL10M-A1-H	10 m	Long bending life	IP65	For HJ-KS/HJ-FS (direct connection type)
	MR-J3ENCBL2M-A1-L	2 m	Standard	IP65	For HJ-KS/HJ-FS (direct connection type)
	MR-J3ENCBL5M-A1-L	5 m	Standard	IP65	For HJ-KS/HJ-FS (direct connection type)
	MR-J3ENCBL10M-A1-L	10 m	Standard	IP65	For HJ-KS/HJ-FS (direct connection type)
Encoder cable (opposite to load-side lead)	MR-J3ENCBL2M-A2-H	2 m	Long bending life	IP65	For HJ-KS/HJ-FS (direct connection type)
	MR-J3ENCBL5M-A2-H	5 m	Long bending life	IP65	For HJ-KS/HJ-FS (direct connection type)
	MR-J3ENCBL10M-A2-H	10 m	Long bending life	IP65	For HJ-KS/HJ-FS (direct connection type)
	MR-J3ENCBL2M-A2-L	2 m	Standard	IP65	For HJ-KS/HJ-FS (direct connection type)
	MR-J3ENCBL5M-A2-L	5 m	Standard	IP65	For HJ-KS/HJ-FS (direct connection type)
	MR-J3ENCBL10M-A2-L	10 m	Standard	IP65	For HJ-KS/HJ-FS (direct connection type)
Encoder cable (load-side lead)	MR-J3JCBL03M-A1-L	0.3 m	Standard	IP20	For HJ-KS/HJ-FS (junction type) ^(Note 1)
Encoder cable (opposite to load-side lead)	MR-J3JCBL03M-A2-L	0.3 m	Standard	IP20	For HJ-KS/HJ-FS (junction type) ^(Note 1)
Encoder cable	MR-EKCBL20M-H	20 m	Long bending life	IP20	For HJ-KS/HJ-FS (junction type) ^(Note 2)
	MR-EKCBL30M-H	30 m	Long bending life	IP20	For HJ-KS/HJ-FS (junction type) ^(Note 2)
	MR-EKCBL40M-H	40 m	Long bending life	IP20	For HJ-KS/HJ-FS (junction type) ^(Note 2)
	MR-EKCBL50M-H	50 m	Long bending life	IP20	For HJ-KS/HJ-FS (junction type) ^(Note 2)
	MR-EKCBL20M-L	20 m	Standard	IP20	For HJ-KS/HJ-FS (junction type) ^(Note 2)
	MR-EKCBL30M-L	30 m	Standard	IP20	For HJ-KS/HJ-FS (junction type) ^(Note 2)
Encoder cable (load-side lead)	MR-J3JSCBL03M-A1-L	0.3 m	Standard	IP65	For HJ-KS/HJ-FS (junction type) ^(Note 3)
Encoder cable (opposite to load-side lead)	MR-J3JSCBL03M-A2-L	0.3 m	Standard	IP65	For HJ-KS/HJ-FS (junction type) ^(Note 3)
Encoder cable	MR-J3ENCBL2M-H	2 m	Long bending life	IP67	For HJ-KS/HJ-FS (junction type) ^(Note 4)
	MR-J3ENCBL5M-H	5 m	Long bending life	IP67	
	MR-J3ENCBL10M-H	10 m	Long bending life	IP67	
	MR-J3ENCBL20M-H	20 m	Long bending life	IP67	
	MR-J3ENCBL30M-H	30 m	Long bending life	IP67	
	MR-J3ENCBL40M-H	40 m	Long bending life	IP67	
	MR-J3ENCBL50M-H	50 m	Long bending life	IP67	
	MR-J3ENCBL2M-L	2 m	Standard	IP67	For HJ-KS/HJ-FS (junction type) ^(Note 4)
	MR-J3ENCBL5M-L	5 m	Standard	IP67	
	MR-J3ENCBL10M-L	10 m	Standard	IP67	
	MR-J3ENCBL20M-L	20 m	Standard	IP67	
	MR-J3ENCBL30M-L	30 m	Standard	IP67	
MR-J3ENCBL40M-L	40 m	Standard	IP67		

Encoder connector set/Junction connector set

Item	Model	Description	IP rating	Application
Encoder connector set	MR-ECNM	Junction connector × 1, Servo amplifier connector × 1	IP20	For HJ-KS/HJ-FS (junction type) ^(Note 2)
Encoder connector set (one-touch connection type)	MR-J3SCNS	Straight type Junction connector or encoder connector × 1, Servo amplifier connector × 1	IP67	For HJ-KS/HJ-FS (junction type) ^(Note 4)

Notes:

1. Use this in combination with MR-EKCBL_M-H, MR-EKCBL_M-L, or MR-ECNM.
2. Use this in combination with MR-J3JCBL03M-A1-L or MR-J3JCBL03M-A2-L.
3. Use this in combination with MR-J3ENCBL_M-H, MR-J3ENCBL_M-L, or MR-J3SCNS.
4. Use this in combination with MR-J3JSCBL03M-A1-L or MR-J3JSCBL03M-A2-L.

Servo motor power cables

Item	Model	Length	Bending life	IP rating	Application
Servo motor power cable (load-side lead, lead-out)	MR-PWS1CBL2M-A1-H	2 m	Long bending life	IP65	For HJ-KS/HJ-FS (direct connection type)
	MR-PWS1CBL5M-A1-H	5 m	Long bending life	IP65	For HJ-KS/HJ-FS (direct connection type)
	MR-PWS1CBL10M-A1-H	10 m	Long bending life	IP65	For HJ-KS/HJ-FS (direct connection type)
	MR-PWS1CBL2M-A1-L	2 m	Standard	IP65	For HJ-KS/HJ-FS (direct connection type)
	MR-PWS1CBL5M-A1-L	5 m	Standard	IP65	For HJ-KS/HJ-FS (direct connection type)
	MR-PWS1CBL10M-A1-L	10 m	Standard	IP65	For HJ-KS/HJ-FS (direct connection type)
Servo motor power cable (opposite to load-side lead, lead-out)	MR-PWS1CBL2M-A2-H	2 m	Long bending life	IP65	For HJ-KS/HJ-FS (direct connection type)
	MR-PWS1CBL5M-A2-H	5 m	Long bending life	IP65	For HJ-KS/HJ-FS (direct connection type)
	MR-PWS1CBL10M-A2-H	10 m	Long bending life	IP65	For HJ-KS/HJ-FS (direct connection type)
	MR-PWS1CBL2M-A2-L	2 m	Standard	IP65	For HJ-KS/HJ-FS (direct connection type)
	MR-PWS1CBL5M-A2-L	5 m	Standard	IP65	For HJ-KS/HJ-FS (direct connection type)
	MR-PWS1CBL10M-A2-L	10 m	Standard	IP65	For HJ-KS/HJ-FS (direct connection type)
Servo motor power cable (load-side lead, lead-out)	MR-PWS2CBL03M-A1-L	0.3 m	Standard	IP55	For HJ-KS/HJ-FS (junction type)
Servo motor power cable (opposite to load-side lead, lead-out)	MR-PWS2CBL03M-A2-L	0.3 m	Standard	IP55	For HJ-KS/HJ-FS (junction type)

Electromagnetic brake cables

Item	Model	Length	Bending life	IP rating	Application
Electromagnetic brake cable (load-side lead, lead-out)	MR-BKS1CBL2M-A1-H	2 m	Long bending life	IP65	For HJ-KS/HJ-FS (direct connection type)
	MR-BKS1CBL5M-A1-H	5 m	Long bending life	IP65	For HJ-KS/HJ-FS (direct connection type)
	MR-BKS1CBL10M-A1-H	10 m	Long bending life	IP65	For HJ-KS/HJ-FS (direct connection type)
	MR-BKS1CBL2M-A1-L	2 m	Standard	IP65	For HJ-KS/HJ-FS (direct connection type)
	MR-BKS1CBL5M-A1-L	5 m	Standard	IP65	For HJ-KS/HJ-FS (direct connection type)
	MR-BKS1CBL10M-A1-L	10 m	Standard	IP65	For HJ-KS/HJ-FS (direct connection type)
Electromagnetic brake cable (opposite to load-side lead, lead-out)	MR-BKS1CBL2M-A2-H	2 m	Long bending life	IP65	For HJ-KS/HJ-FS (direct connection type)
	MR-BKS1CBL5M-A2-H	5 m	Long bending life	IP65	For HJ-KS/HJ-FS (direct connection type)
	MR-BKS1CBL10M-A2-H	10 m	Long bending life	IP65	For HJ-KS/HJ-FS (direct connection type)
	MR-BKS1CBL2M-A2-L	2 m	Standard	IP65	For HJ-KS/HJ-FS (direct connection type)
	MR-BKS1CBL5M-A2-L	5 m	Standard	IP65	For HJ-KS/HJ-FS (direct connection type)
	MR-BKS1CBL10M-A2-L	10 m	Standard	IP65	For HJ-KS/HJ-FS (direct connection type)
Electromagnetic brake cable (load-side lead, lead-out)	MR-BKS2CBL03M-A1-L	0.3 m	Standard	IP55	For HJ-KS/HJ-FS (junction type)
Electromagnetic brake cable (opposite to load-side lead, lead-out)	MR-BKS2CBL03M-A2-L	0.3 m	Standard	IP55	For HJ-KS/HJ-FS (junction type)

Junction terminal block/Junction terminal block cables

Item	Model	Length	Application
Junction terminal block (50 pins)	MR-TB50	-	For MR-JE-AS
Junction terminal block cable (for MR-TB50)	MR-J2M-CN1TBL05M	0.5 m	For connecting MR-JE-AS and MR-TB50
	MR-J2M-CN1TBL1M	1 m	For connecting MR-JE-AS and MR-TB50

Regenerative options

Item	Model	Specification	Application
Regenerative option	MR-RB032	Permissible regenerative power: 30 W, Resistance value: 40 Ω	For MR-JE-10AS to MR-JE-100AS
	MR-RB12	Permissible regenerative power: 100 W, Resistance value: 40 Ω	For MR-JE-20AS to MR-JE-100AS
	MR-RB30	Permissible regenerative power: 300 W, Resistance value: 13 Ω	For MR-JE-200AS
	MR-RB32	Permissible regenerative power: 300 W, Resistance value: 40 Ω	For MR-JE-70AS and MR-JE-100AS
	MR-RB50	Permissible regenerative power: 500 W, Resistance value: 13 Ω	For MR-JE-200AS

Product list

Peripheral cable

Item	Model	Length	Application
Personal computer communication cable (USB cable)	MR-J3USBCBL3M	3 m	For MR-JE-AS

Peripheral connectors

Item	Model	Description	Application
Servo amplifier CNP1 power connector ^(Note 1) (insertion type)	MR-JECNP1-01	CNP1 connector × 1, Open tool × 1	For MR-JE-10AS to MR-JE-100AS
	MR-JECNP1-02	CNP1 connector × 1, Open tool × 1	For MR-JE-200AS
Servo amplifier CNP2 power connector ^(Note 1) (insertion type)	MR-JECNP2-02	CNP2 connector × 1	For MR-JE-200AS
Connector set	MR-J3CN1	Servo amplifier connector × 1	For I/O signals of MR-JE-AS

Servo support software

Item	Model	Application
MR Configurator2	SW1DNC-MRC2-E	Servo setup software for AC servo

Notes:

1. CNP1 and CNP2 connectors, and the open tool are supplied with the servo amplifier.

To ensure safe use

- To use the products given in this catalog properly, always read the "Installation Guide" and "Instruction Manual" before starting to use them.

Cautions for model selection

- Select a servo motor which has the rated torque equal to or higher than the continuous effective torque.
- When unbalanced torque is generated, such as in a vertical lift machine, keep the unbalanced torque of the machine under 70% of the servo motor rated torque.
- Create the operating pattern by considering the settling time (t_s).
- Load to motor inertia ratio must be below the recommended ratio. If the ratio is too large, the expected performance may not be achieved, and the dynamic brake may be damaged.

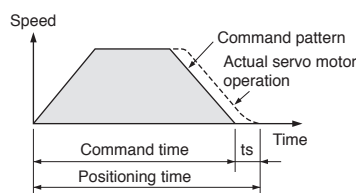

General safety precautions

1. Transportation/installation

- Combinations of the servo motor and the servo amplifier are predetermined. Confirm the models of the servo motor and the servo amplifier to be used before installation.
- Do not drop or apply strong impact on the servo amplifier and the servo motor as they are precision devices. They may be damaged from such stress or shock.
- When fumigants that contain halogen materials such as fluorine, chlorine, bromine, and iodine are used for disinfecting and protecting wooden packaging from insects, they cause malfunction when entering our products. Please take necessary precautions to ensure that remaining materials from fumigant do not enter our products, or treat packaging with methods other than fumigation (heat method). Additionally, disinfect and protect wood from insects before packing products.
- Do not get on or place heavy objects on the servo amplifier or the servo motor. Doing so may result in injury or damage.
- The system must withstand high speeds and high acceleration/ deceleration.
- To enable high-accuracy positioning, ensure the machine rigidity, and keep the machine resonance point at a high level.
- Mount the servo amplifier and the servo motor on nonflammable material. Mounting them directly on or near flammable material may result in fires.
- The regenerative option becomes hot (the temperature rise of 100 °C or higher) with frequent use. Do not install within flammable objects or objects subject to thermal deformation. Make sure that wires do not come into contact with the unit.
- Securely fix the servo motor onto the machine. Insufficient fixing may cause the servo motor to dislocate during operation.
- Install electrical and mechanical stoppers at the stroke end.
- Mount the servo amplifier vertically on a wall.
- Do not block intake and exhaust areas of the servo amplifier. Doing so may cause the servo amplifier to malfunction.
- When installing multiple servo amplifiers in a row in a sealed cabinet, leave space around the servo amplifiers as described in Servo Amplifier Instruction Manual. To ensure the life and reliability of the servo amplifiers, prevent heat accumulation by keeping space as open as possible toward the top plate.

2. Environment

- Use the servo amplifier and the servo motor in the designated environment.

- Avoid installing the servo amplifier and the servo motor in areas with oil mist or dust. When installing in such areas, be sure to enclose the servo amplifier in a sealed cabinet, and protect the servo motor by furnishing a cover or by taking similar measures.
- Do not use in areas where the servo motor may be constantly subject to cutting fluid or lubricant oil, or where dew could condense because of oil mist, overcooling or excessive humidity. Doing so may deteriorate the insulation of the servo motor.

3. Grounding

- Securely ground to prevent electric shocks and to stabilize the potential in the control circuit.
- Connect the grounding wire to the cabinet protective earth (PE) terminal via the servo amplifier protective earth (PE) terminal for the servo motor grounding.
- Faults such as a position mismatch may occur if the grounding is insufficient.

4. Wiring

- Do not supply power to the output terminals (U, V, and W) of the servo amplifier or the input terminals (U, V, and W) of the servo motor. Doing so damages the servo amplifier and the servo motor.
- Connect the servo motor to the output terminals (U, V, and W) of the servo amplifier.
- Match the phase of the input terminals (U, V, and W) of the servo motor to the output terminals (U, V, and W) of the servo amplifier when connecting them. If they do not match, the servo motor does not operate properly.
- Check the wiring and sequence program thoroughly before switching the power on.
- Carefully select the cable clamping method, and make sure that bending stress and the stress of the cable's own weight are not applied on the cable connection section.
- In an application where the servo motor moves, determine the cable bending radius according to the cable bending life and wire type.

5. Initial settings

- For MR-JE-AS, select a control mode from position, speed or torque with [Pr. PA01]. Position control mode is set as default. Change the parameter setting value when using the other control modes.
- When using the regenerative option, change [Pr. PA02]. The regenerative option is disabled as default.

6. Operation

- Do not use a product which is damaged or has missing parts. In that case, replace the product.
- Turn on LSP and LSN (Forward/Reverse rotation stroke end) in position or speed control mode. The servo motor will not start if the signals are off.
- When a magnetic contactor is installed on the primary side of the servo amplifier, do not perform frequent starts and stops with the magnetic contactor. Doing so may damage the servo amplifier.
- When an error occurs, the servo amplifier stops outputting the power with activation of the protective function, and the servo motor stops immediately with the dynamic brake.
- The dynamic brake is a function for emergency stop. Do not use it to stop the servo motor in normal operations.
- As a rough guide, the dynamic brake withstands 1000 times of use when a machine which has load to motor inertia ratio equals to or lower than the recommended ratio stops from the rated speed every 10 minutes.
- If the protective functions of the servo amplifier activate, turn the power off immediately. Remove the cause before turning the power on again. If operation is continued without removing the cause of the error, the servo motor may malfunction, resulting in injury or damage.

Cautions

- The servo amplifier, the regenerative resistor, and the servo motor can be very hot during or after operation. Take safety measures such as covering them to prevent your hand and/or parts including cables from coming in contact with them.

7. Others

- Do not touch the servo amplifier or the servo motor with wet hands.
- Do not modify the servo amplifier or the servo motor.

Cautions for servo motors

- Do not hammer the shaft of the servo motor when installing a pulley or a coupling. Doing so may damage the encoder. When installing the pulley or the coupling to the key shaft servo motor, use the screw hole on the shaft end. Use a pulley extractor when removing the pulley.
- Do not apply a load exceeding the tolerable load onto the servo motor shaft. The shaft may break.
- When the servo motor is mounted with the shaft vertical (shaft up), take measures on the machine side so that oil from the gear box does not get into the servo motor.
- Do not use the 24 V DC interface power supply for the electromagnetic brake. Provide a dedicated power supply to the electromagnetic brake.
- Do not apply the electromagnetic brake when the servo is on. Doing so may cause the servo amplifier overload or shorten the brake life. Apply the electromagnetic brake when the servo is off.
- Torque may drop due to temperature increase of the servo motor. Be sure to use the motor within the specified ambient temperature.

Warranty

1. Warranty period and coverage

We will repair any failure or defect hereinafter referred to as "failure" in our FA equipment hereinafter referred to as the "Product" arisen during warranty period at no charge due to causes for which we are responsible through the distributor from which you purchased the Product or our service provider. However, we will charge the actual cost of dispatching our engineer for an on-site repair work on request by customer in Japan or overseas countries. We are not responsible for any on-site readjustment and/or trial run that may be required after a defective unit is repaired or replaced.

[Term]

The term of warranty for Product is twelve (12) months after your purchase or delivery of the Product to a place designated by you or eighteen (18) months from the date of manufacture whichever comes first ("Warranty Period"). Warranty period for repaired Product cannot exceed beyond the original warranty period before any repair work.

[Limitations]

- (1) You are requested to conduct an initial failure diagnosis by yourself, as a general rule. It can also be carried out by us or our service company upon your request and the actual cost will be charged. However, it will not be charged if we are responsible for the cause of the failure.
- (2) This limited warranty applies only when the condition, method, environment, etc. of use are in compliance with the terms and conditions and instructions that are set forth in the instruction manual and user manual for the Product and the caution label affixed to the Product.
- (3) Even during the term of warranty, the repair cost will be charged on you in the following cases;
 - (i) a failure caused by your improper storing or handling, carelessness or negligence, etc., and a failure caused by your hardware or software problem
 - (ii) a failure caused by any alteration, etc. to the Product made on your side without our approval
 - (iii) a failure which may be regarded as avoidable, if your equipment in which the Product is incorporated is equipped with a safety device required by applicable laws and has any function or structure considered to be indispensable according to a common sense in the industry
 - (iv) a failure which may be regarded as avoidable if consumable parts designated in the instruction manual, etc. are duly maintained and replaced
 - (v) any replacement of consumable parts (battery, fan, smoothing capacitor, etc.)
 - (vi) a failure caused by external factors such as inevitable accidents, including without limitation fire and abnormal fluctuation of voltage, and acts of God, including without limitation earthquake, lightning and natural disasters
 - (vii) a failure generated by an unforeseeable cause with a scientific technology that was not available at the time of the shipment of the Product from our company
 - (viii) any other failures which we are not responsible for or which you acknowledge we are not responsible for

2. Term of warranty after the stop of production

- (1) We may accept the repair at charge for another seven (7) years after the production of the product is discontinued. The announcement of the stop of production for each model can be seen in our Sales and Service, etc.
- (2) Please note that the Product (including its spare parts) cannot be ordered after its stop of production.

3. Service in overseas countries

Our regional FA Center in overseas countries will accept the repair work of the Product. However, the terms and conditions of the repair work may differ depending on each FA Center. Please ask your local FA Center for details.

4. Exclusion of loss in opportunity and secondary loss from warranty liability

Regardless of the gratis warranty term, Mitsubishi shall not be liable for compensation to:

- (1) Damages caused by any cause found not to be the responsibility of Mitsubishi.
- (2) Loss in opportunity, lost profits incurred to the user by Failures of Mitsubishi products.
- (3) Special damages and secondary damages whether foreseeable or not, compensation for accidents, and compensation for damages to products other than Mitsubishi products.
- (4) Replacement by the user, maintenance of on-site equipment, start-up test run and other tasks.

5. Change of Product specifications

Specifications listed in our catalogs, manuals or technical documents may be changed without notice.

6. Application and use of the Product

- (1) For the use of our General-Purpose AC Servo, its applications should be those that may not result in a serious damage even if any failure or malfunction occurs in General-Purpose AC Servo, and a backup or fail-safe function should operate on an external system to General-Purpose AC Servo when any failure or malfunction occurs.
- (2) Our General-Purpose AC Servo is designed and manufactured as a general purpose product for use at general industries. Therefore, applications substantially influential on the public interest for such as atomic power plants and other power plants of electric power companies, and also which require a special quality assurance system, including applications for railway companies and government or public offices are not recommended, and we assume no responsibility for any failure caused by these applications when used.

In addition, applications which may be substantially influential to human lives or properties for such as airlines, medical treatments, railway service, incineration and fuel systems, man-operated material handling equipment, entertainment machines, safety machines, etc. are not recommended, and we assume no responsibility for any failure caused by these applications when used.

We will review the acceptability of the abovementioned applications, if you agree not to require a specific quality for a specific application. Please contact us for consultation.

Global FA Centers

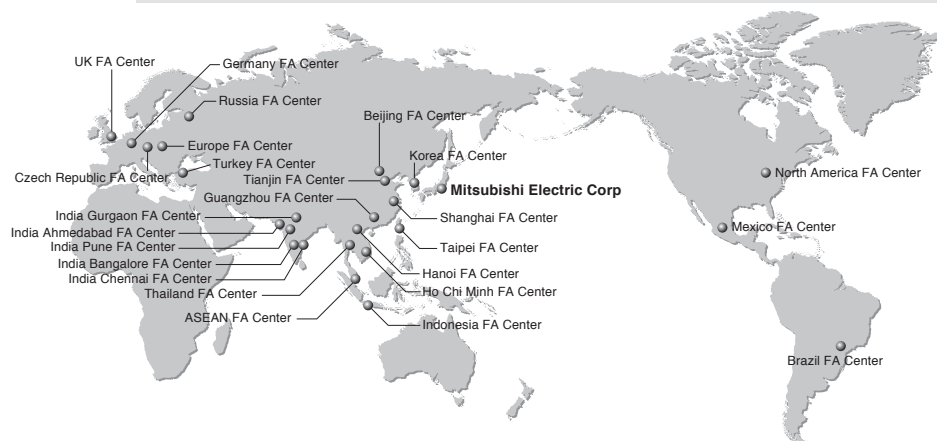

China

Shanghai FA Center
Mitsubishi Electric Automation
(China) Ltd. Shanghai FA Center
 Mitsubishi Electric Automation Center,
 No.1386 Hongqiao Road, Shanghai, China
 Tel: 86-21-2322-3030 Fax: 86-21-2322-3000 (9611#)

Beijing FA Center
Mitsubishi Electric Automation
(China) Ltd. Beijing FA Center
 Unit 901, Office Tower 1, Henderson Centre,
 18 Jianguomennei Avenue, Dongcheng District,
 Beijing, China
 Tel: 86-10-6518-8830 Fax: 86-10-6518-2938

Tianjin FA Center
Mitsubishi Electric Automation
(China) Ltd. Tianjin FA Center
 Room 2003 City Tower, No.35, Youyi Road,
 Hexi District, Tianjin, China
 Tel: 86-22-2813-1015 Fax: 86-22-2813-1017

Guangzhou FA Center
Mitsubishi Electric Automation
(China) Ltd. Guangzhou FA Center
 Room 1609, North Tower, The Hub Center,
 No.1068, Xingang East Road, Haizhu District,
 Guangzhou, China
 Tel: 86-20-8923-6730 Fax: 86-20-8923-6715

Taiwan

Taipei FA Center
SETSUYO ENTERPRISE CO., LTD.
 3F, No.105, Wugong 3rd Road, Wugu District,
 New Taipei City 24889, Taiwan
 Tel: 886-2-2299-9917 Fax: 886-2-2299-9963

Korea

Korea FA Center
Mitsubishi Electric Automation
Korea Co., Ltd.
 7F-9F, Gangseo Hangang Xi-tower A, 401,
 Yangcheon-ro, Gangseo-Gu, Seoul 07528, Korea
 Tel: 82-2-3660-9605 Fax: 82-2-3664-0475

Thailand

Thailand FA Center
Mitsubishi Electric Factory Automation
(Thailand) Co., Ltd.
 12th Floor, SV.City Building, Office Tower 1,
 No. 896/19 and 20 Rama 3 Road,
 Kwaeng Bangpoo, Khet Yannawa, Bangkok
 10120, Thailand
 Tel: 66-2682-6522 to 6531 Fax: 66-2682-6020

ASEAN

ASEAN FA Center
Mitsubishi Electric Asia Pte. Ltd.
 307 Alexandra Road, Mitsubishi Electric Building,
 Singapore 159943
 Tel: 65-6470-2475 Fax: 65-6476-7439

Indonesia

Indonesia FA Center
PT. Mitsubishi Electric Indonesia
Cikarang Office
 Jl. Kenari Raya Blok G2-07A Delta Silicon 5,
 Lippo Cikarang - Bekasi 17550, Indonesia
 Tel: 62-21-2961-7797 Fax: 62-21-2961-7794

Vietnam

Hanoi FA Center
Mitsubishi Electric Vietnam Company
Limited Hanoi Branch Office
 6th Floor, Detech Tower, 8 Ton That Thuyet Street,
 My Dinh2 Ward, Nam Tu Liem District, Hanoi,
 Vietnam
 Tel: 84-4-3937-8075 Fax: 84-4-3937-8076

Ho Chi Minh FA Center
Mitsubishi Electric Vietnam Company Limited
 Unit 01-04, 10th Floor, Vincom Center, 72 Le
 Thanh Ton Street, District 1, Ho Chi Minh City,
 Vietnam
 Tel: 84-8-3910-5945 Fax: 84-8-3910-5947

India

India Pune FA Center
Mitsubishi Electric India Pvt. Ltd.
Pune Branch
 Emerald House, EL-3, J Block, M.I.D.C., Bhosari,
 Pune - 411026, Maharashtra, India
 Tel: 91-20-2710-2000 Fax: 91-20-2710-2100

India Gurgaon FA Center
Mitsubishi Electric India Pvt. Ltd.
Gurgaon Head Office
 2nd Floor, Tower A & B, Cyber Greens, DLF
 Cyber City, DLF Phase - III, Gurgaon - 122002,
 Haryana, India
 Tel: 91-124-463-0300 Fax: 91-124-463-0399

India Bangalore FA Center
Mitsubishi Electric India Pvt. Ltd.
Bangalore Branch
 Prestige Emerald, 6th Floor, Municipal No.2,
 Madras Bank Road, Bangalore - 560001,
 Karnataka, India
 Tel: 91-80-4020-1600 Fax: 91-80-4020-1699

India Chennai FA Center
Mitsubishi Electric India Pvt. Ltd.
Chennai Branch
 Citilights Corporate Centre No. 1,
 Vivekananda Road, Srinivasa Nagar, Chetpet,
 Chennai - 600031, Tamil Nadu, India
 Tel: 91-4445548772 Fax: 91-4445548773

India Ahmedabad FA Center
Mitsubishi Electric India Pvt. Ltd.
Ahmedabad Branch
 B/4, 3rd Floor, SAFAL Profitaire, Corporate Road,
 Prahaladnagar, Satellite, Ahmedabad - 380015,
 Gujarat, India
 Tel: 91-7965120063 Fax: -

America

North America FA Center
Mitsubishi Electric Automation, Inc.
 500 Corporate Woods Parkway, Vernon Hills,
 IL 60061, U.S.A.
 Tel: 1-847-478-2100 Fax: 1-847-478-2253

Mexico

Mexico FA Center
Mitsubishi Electric Automation, Inc.
Mexico Branch
 Mariano Escobedo #69, Col.Zona Industrial,
 Tlalneantla Edo. Mexico, C.P.54030
 Tel: 52-55-3067-7511 Fax: -

Brazil

Brazil FA Center
Mitsubishi Electric do Brasil
Comercio e Servicos Ltda.
 Avenida Adelino Cardana, 293, 21 andar, Bethaville,
 Barueri SP, Brazil
 Tel: 55-11-4689-3000 Fax: 55-11-4689-3016

Europe

Europe FA Center
Mitsubishi Electric Europe B.V.
Polish Branch
 ul. Krakowska 50, 32-083 Balice, Poland
 Tel: 48-212-347-65-00 Fax: 48-212-630-47-01

Germany FA Center
Mitsubishi Electric Europe B.V.
German Branch
 Gothaer Strasse 8, D-40880 Ratingen, Germany
 Tel: 49-2102-486-0 Fax: 49-2102-486-1120

UK FA Center
Mitsubishi Electric Europe B.V.
UK Branch
 Travellers Lane, Hatfield, Hertfordshire, AL10
 8XB, U.K.
 Tel: 44-1707-27-8780 Fax: 44-1707-27-8695

Czech Republic FA Center
Mitsubishi Electric Europe B.V.
Czech Branch
 Avenir Business Park, Radlicka 751/113e,
 158 00 Praha5, Czech Republic
 Tel: 420-251-551-470 Fax: 420-251-551-471

Russia FA Center
Mitsubishi Electric (Russia) LLC
St. Petersburg Branch
 Piskarevsky pr. 2, bld 2, lit "Sch", BC "Benua",
 office 720; 195027, St. Petersburg, Russia
 Tel: 7-812-633-3497 Fax: 7-812-633-3499

Turkey FA Center
Mitsubishi Electric Turkey A.S.
Umraniye Branch
 Serifali Mahallesi Nutuk Sokak No:5,
 TR-34775 Umraniye / Istanbul, Turkey
 Tel: 90-216-526-3990 Fax: 90-216-526-3995

MEMO

Microsoft, Windows, Internet Explorer, and Windows Vista are either registered trademarks or trademarks of Microsoft Corporation in the United States and/or other countries.
Celeron and Pentium are registered trademarks of Intel Corporation in the U.S. and/or other countries.
All other company names and product names used in this document are trademarks or registered trademarks of their respective companies.

 **Safety Warning**

To ensure proper use of the products listed in this catalog,
please be sure to read the instruction manual prior to use.



YOUR SOLUTION PARTNER

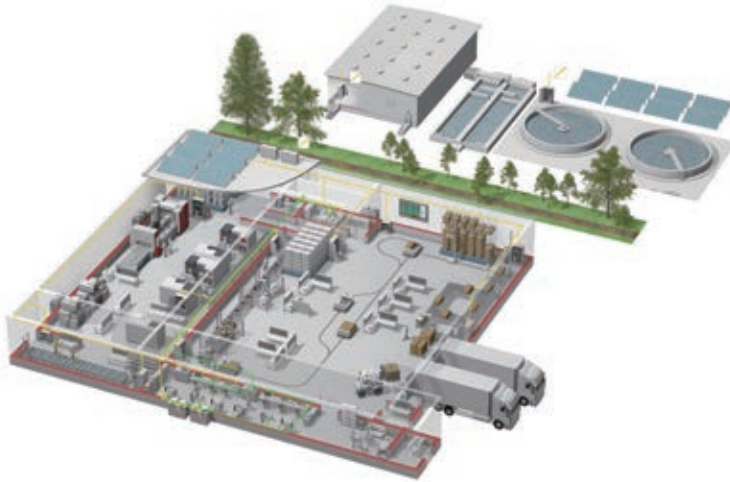

Mitsubishi Electric offers a wide range of automation equipment from PLCs and HMIs to CNC and EDM machines.

A NAME TO TRUST

Since its beginnings in 1870, some 45 companies use the Mitsubishi name, covering a spectrum of finance, commerce and industry.

The Mitsubishi brand name is recognized around the world as a symbol of premium quality.

Mitsubishi Electric Corporation is active in space development, transportation, semi-conductors, energy systems, communications and information processing, audio visual equipment and home electronics, building and energy management and automation systems, and has 237 factories and laboratories worldwide in over 121 countries.

This is why you can rely on Mitsubishi Electric automation solution - because we know first hand about the need for reliable, efficient, easy-to-use automation and control in our own factories.

As one of the world's leading companies with a global turnover of over 4 trillion Yen (over \$40 billion), employing over 100,000 people, Mitsubishi Electric has the resource and the commitment to deliver the ultimate in service and support as well as the best products.

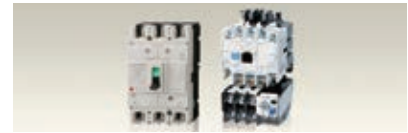

Low voltage: MCCB, MCB, ACB



Medium voltage: VCB, VCC



Power monitoring, energy management



Compact and Modular Controllers



Inverters, Servos and Motors



Visualisation: HMIs



Numerical Control (NC)



Robots: SCARA, Articulated arm



Processing machines: EDM, Lasers, IDS



Transformers, Air conditioning, Photovoltaic systems

* Not all products are available in all countries.

SERVO AMPLIFIERS & MOTORS

Country/Region	Sales office	Tel/Fax
USA	Mitsubishi Electric Automation, Inc. 500 Corporate Woods Parkway, Vernon Hills, IL 60061, U.S.A.	Tel : +1-847-478-2100 Fax : +1-847-478-2253
Mexico	Mitsubishi Electric Automation, Inc. Mexico Branch Mariano Escobedo #69, Col.Zona Industrial, Tlalnepantla Edo. Mexico, C.P.54030	Tel : +52-55-3067-7500 Fax : -
Brazil	Mitsubishi Electric do Brasil Comercio e Servicos Ltda. Avenida Adelino Cardana, 293, 21 andar, Bethaville, Barueri SP, Brazil	Tel : +55-11-4689-3000 Fax : +55-11-4689-3016
Germany	Mitsubishi Electric Europe B.V. German Branch Mitsubishi-Electric-Platz 1, 40882 Ratingen, Germany	Tel : +49-2102-486-0 Fax : +49-2102-486-1120
UK	Mitsubishi Electric Europe B.V. UK Branch Travellers Lane, UK-Hatfield, Hertfordshire, AL10 8XB, U.K.	Tel : +44-1707-28-8780 Fax : +44-1707-27-8695
Italy	Mitsubishi Electric Europe B.V. Italian Branch Centro Direzionale Colleoni - Palazzo Sirio, Viale Colleoni 7, 20864 Agrate Brianza (MB), Italy Brianza (Milano), Italy	Tel : +39-039-60531 Fax : +39-039-6053-312
Spain	Mitsubishi Electric Europe B.V. Spanish Branch Carretera de Rubi, 76-80-Apdo. 420, 08190 Sant Cugat del Valles (Barcelona), Spain	Tel : +34-935-65-3131 Fax : +34-935-89-1579
France	Mitsubishi Electric Europe B.V. French Branch 25, Boulevard des Bouvets, 92741 Nanterre Cedex, France	Tel : +33-1-55-68-55-68 Fax : +33-1-55-68-57-57
Czech Republic	Mitsubishi Electric Europe B.V. Czech Branch Avenir Business Park, Radlicka 751/113e, 158 00 Praha 5, Czech Republic	Tel : +420-251-551-470 Fax : +420-251-551-471
Poland	Mitsubishi Electric Europe B.V. Polish Branch ul. Krakowska 50, 32-083 Balice, Poland	Tel : +48-12-347-65-00 Fax : +48-12-630-47-01
Russia	Mitsubishi Electric (Russia) LLC St. Petersburg Branch Piskarevsky pr. 2, bld 2, lit "Sch", BC "Benua", office 720; 195027 St. Petersburg, Russia	Tel : +7-812-633-3497 Fax : +7-812-633-3499
Sweden	Mitsubishi Electric Europe B.V. (Scandinavia) Fjellievagen 8, SE-22736 Lund, Sweden	Tel : +46-8-625-10-00 Fax : +46-46-39-70-18
Turkey	Mitsubishi Electric Turkey A.S. Umraniye Branch Serifali Mahallesi Nutuk Sokak No:5, TR-34775 Umraniye / Istanbul, Turkey	Tel : +90-216-526-3990 Fax : +90-216-526-3995
UAE	Mitsubishi Electric Europe B.V. Dubai Branch Dubai Silicon Oasis, P.O.BOX 341241, Dubai, U.A.E.	Tel : +971-4-3724716 Fax : +971-4-3724721
South Africa	Adroit Technologies 20 Waterford Office Park, 189 Witkoppen Road, Fourways, South Africa	Tel : +27-11-658-8100 Fax : +27-11-658-8101
China	Mitsubishi Electric Automation (China) Ltd. Mitsubishi Electric Automation Center, No.1386 Hongqiao Road, Shanghai, China	Tel : +86-21-2322-3030 Fax : +86-21-2322-3000
Taiwan	SETSUYO ENTERPRISE CO., LTD. 6F, No.105, Wugong 3rd Road, Wugu District, New Taipei City 24889, Taiwan	Tel : +886-2-2299-2499 Fax : +886-2-2299-2509
Korea	Mitsubishi Electric Automation Korea Co., Ltd. 7F-9F, Gangseo Hangang Xi-tower A, 401, Yangcheon-ro, Gangseo-Gu, Seoul 07528, Korea	Tel : +82-2-3660-9510 Fax : +82-2-3664-8372/8335
Singapore	Mitsubishi Electric Asia Pte. Ltd. 307 Alexandra Road, Mitsubishi Electric Building, Singapore 159943	Tel : +65-6473-2308 Fax : +65-6476-7439
Thailand	Mitsubishi Electric Factory Automation (Thailand) Co., Ltd. 12th Floor, SV.City Building, Office Tower 1, No. 896/19 and 20 Rama 3 Road, Kwaeng Bangpongpan, Khet Yannawa, Bangkok 10120, Thailand	Tel : +66-2682-6522 to 6531 Fax : +66-2682-6020
Indonesia	PT. Mitsubishi Electric Indonesia Gedung Jaya 11th Floor, JL. MH. Thamrin No.12, Jakarta Pusat 10340, Indonesia	Tel : +62-21-3192-6461 Fax : +62-21-3192-3942
Vietnam	Mitsubishi Electric Vietnam Company Limited Unit 01-04, 10th Floor, Vincom Center, 72 Le Thanh Ton Street, District 1, Ho Chi Minh City, Vietnam	Tel : +84-8-3910-5945 Fax : +84-8-3910-5947
India	Mitsubishi Electric India Pvt. Ltd. Pune Branch Emerald House, EL-3, J Block, M.I.D.C., Bhosari, Pune - 411026, Maharashtra, India	Tel : +91-20-2710-2000 Fax : +91-20-2710-2100
Australia	Mitsubishi Electric Australia Pty. Ltd. 348 Victoria Road, P.O. Box 11, Rydalmere, N.S.W 2116, Australia	Tel : +61-2-9684-7777 Fax : +61-2-9684-7245

Mitsubishi Electric Corporation Nagoya Works is a factory certified for ISO 14001 (standards for environmental management systems) and ISO 9001 (standards for quality assurance management systems).

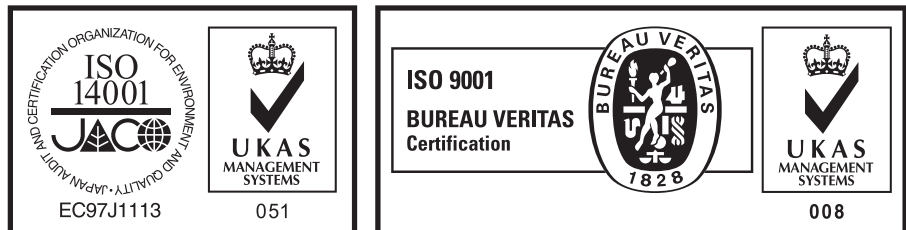

MITSUBISHI ELECTRIC CORPORATION

HEAD OFFICE: TOKYO BUILDING, 2-7-3, MARUNOUCHI, CHIYODA-KU, TOKYO 100-8310, JAPAN
NAGOYA WORKS: 1-14, YADA-MINAMI 5, HIGASHI-KU, NAGOYA, JAPAN